

<u>Contents</u>	<u>Page</u>
1 . Pipe material	1
2 . Axles	2
3 . Load capacity diagram	3
4 . Description accumulation/friction rollers	4
5 . Gravity conveyor rollers	6-33
6 . Stub roller	35
7 . Conveyor belt drums	36
8 . Powered conveyor rollers with belt grooves	37-38
9 . Powered conveyor rollers with tooth belt drive	39-40
10 . Tooth belts and motor drive wheels	41
11 . Powered accumulation conveyor rollers with flat belt drive	42
12 . Powered conveyor rollers with multi-ribbed belt wheel	43
13 . Powered conveyor rollers with single chain wheel	44-59
14 . Powered conveyor rollers with adjustable friction	48-49 / 65-66
15 . Centre distance	60
16 . Powered conveyor rollers with double chain wheel	62-70
17 . Conical conveyor rollers	71
18 . Conical gravity conveyor rollers	72
19 . Conical conveyor rollers with single chain wheel	73
20 . Conical conveyor rollers with double chain wheel	74
21 . Conical conveyor rollers with multi-ribbed belt wheel	76
22 . Conical conveyor roller with belt grooves	77
23 . Conical conveyor roller with round belt drive	78
24 . Guide discs, buffer rings, back up rings	79
25 . Push-on caps	80
26 . Mini roller	82
27 . Conveyor wheels	83
28 . Roller strips	84-86
29 . Roller tracks	87-92
30 . Brake rollers	93-94
31 . Clutch brake system KB1512	95-96
32 . Roller dimensions	97-106
33 . PEKO inquiry form	108
34 . Terms of sale and delivery	

# Pipe material

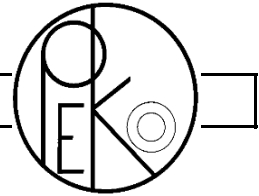

Order reference	Material
<b>S</b>	Steel pipe EN 10305-3
<b>SV</b>	Steel pipe galvanised
<b>SG</b>	Steel pipe rubberised
<b>SP</b>	Steel pipe with PVC-Coating (PVC 65° Shore silver grey)
<b>N</b>	Stainless Steel pipe (Niro) W No.1.4301
<b>PG</b>	Plastic pipe PVC gray RAL 7011
<b>PB</b>	Plastic pipe PVC blue RAL 5010
<b>ALU</b>	Aluminium pipe AlMgSi 0.5

Pipe-Ø <b>RD</b>	Wall thickness <b>WS</b>	Pipe weight in kg/m							
		<b>S</b>	<b>SV</b>	<b>SG</b>	<b>SP</b>	<b>N</b>	<b>PG</b>	<b>PB</b>	<b>ALU</b>
16,0	1,0	0,370	0,370	○		0,370			
20,0	1,5	0,684	0,684	○		0,684		0,137	0,235
30,0	1,0	0,715	0,715	○	●	0,715			
	1,5	1,054	1,054	○	●				
	1,8						0,245	0,245	
32,0	2,0	1,480	1,480	○	●	1,480			
40,0	1,5	1,425	1,425	○	●	1,425			
	2,3						0,419		
	3,0	2,737	2,737	○	●				
48,0	1,5	1,720	1,720	○					
	2,0	2,269	2,269	○					
50,0	1,5	1,794	1,794	○	●	1,794			0,617
	2,0	2,368	2,368	○	●	2,368			
	2,8						0,640	0,640	
	3,0	3,477	3,477	○	●				
60,0	1,5	2,164	2,164	○	●				
	2,0	2,861	2,861	○	●				
	3,0	4,217	4,217	○	●				
60,3	1,65				●	2,385			
63,0	3,0						0,870		
63,5	2,9	4,334	4,334	○	●				
70,0	2,0	3,354	3,354	○					1,154
80,0	2,0	3,847	3,847	○	●	3,847			
	3,0	5,696	5,696	○	●				
88,9	2,9	6,151	6,151			6,151			
108,0	3,6	9,272	9,272	○		9,272			
133,0	4,0	12,730	12,730	○					
159,0	4,5	17,153	17,153	○					

- hardened and/or polished designs upon request
- weight of coated pipe is dependent on the coating
- chromium-plated, nickel-plated or black-finished designs upon request
- designs with sound-absorbing inserts upon request

Other designs upon request.

- -Design upon request
- -In the standard

Ordering example      30x1,8 PG (Pipe Ø30, Wall thickness 1.8mm material PVC gray)  
 50x1,5 N (Pipe Ø50, Wall thickness 1.5mm material Niro)

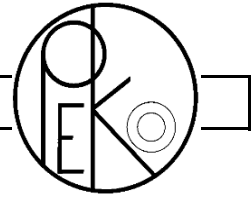

## Static load of the axles

with fixed clamping

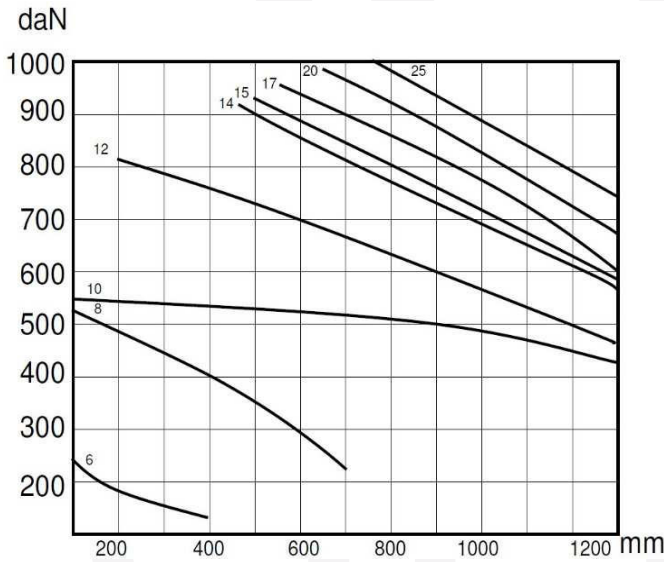

with looser clamping

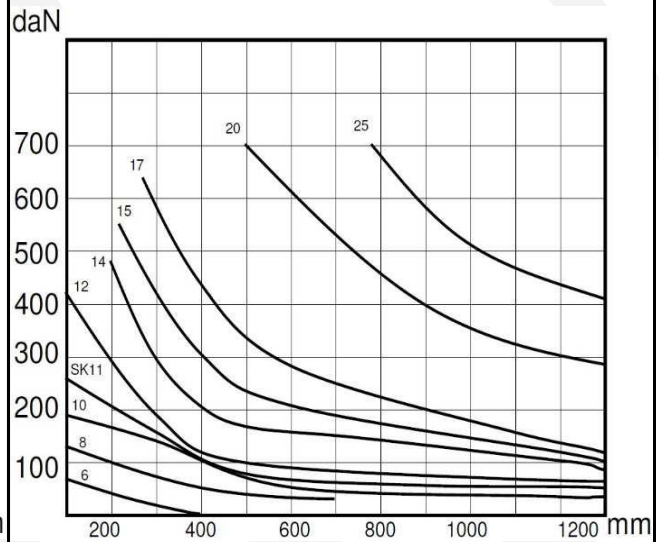

## Static area load of the pipes

Steel pipe

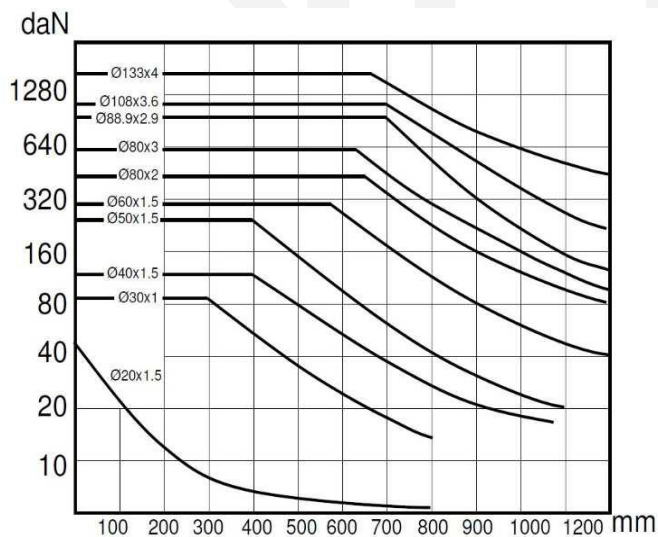

Plastic pipe

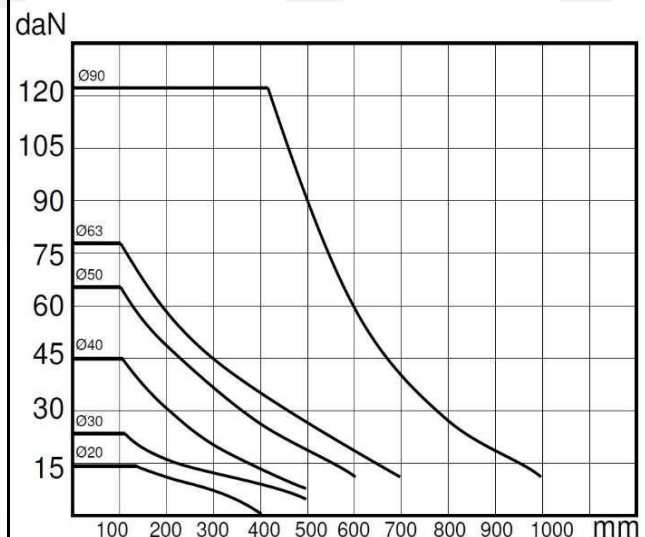

Other dimensions upon request.

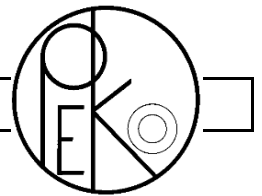

### Function:

The drive element is continually powered via chains, tooth belts, flat belts or other types of drives. An anti-friction bushing is located between the drive element and the roller and there is thus no fixed connection between the drive and roller. The continual drive is transferred via the friction within the anti-friction bushing onto the roller. The drive force is dependent on the goods to be conveyed and the associated weight. If the goods being conveyed are stopped during an accumulation operation, the roller stops with good placement of the goods being conveyed although the drive element continues to turn. Friction between the drive element and the anti-friction bushing results which passes a certain dynamic pressure to the goods being conveyed. The material used by the drive element and anti-friction bushing such as plastic, steel, lubrication, etc. plays a major role. With an increasing accumulation length, the dynamic pressure can accumulate.

### Drive force:

The drive force is dependent on various factors such as, for example, composition of the ground and weight of the goods being conveyed, location of the contact points of the conveyed goods to the rollers, conveying speed, temperature, lubrication, humidity, ratio of the accumulation operation to the entire operation time, etc.

### Conveying speed:

The allowed conveying speed is from 0.15 to 0.5m/sec.

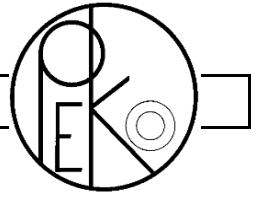

# Gravity conveyor roller

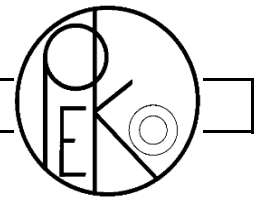

## ST-001 / ST-001N

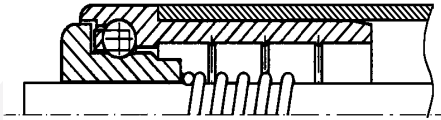

Conveyor roller bearings of thermoplastic material with row of balls. The balls are available in steel (ST-001) or Niro W no. 1.4034 (ST-001N).

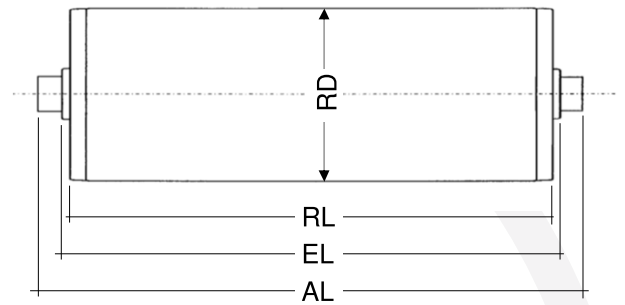

Pipe-Ø	Axle-Ø	Pipe design								Maximum load bearing capacity per roller*							
		S	SV	SG	SP	N	PG	PB	ALU	001	001N						
16x1	6	●	●	○		●				6	6						14
20x1,5	6,8	●	●	○		●	●	●		10	10						16
30x1	6,8,10	●	●	○	●	●				14	14						16
30x1,5	6,8,10	●	●	○	●	●				14	14						16
30x1,8	6,8,10						●	●		14	14						16
40x1,5	6,8,10	●	●	○	●	●				14	14						16
40x2,3	6,8,10						●	●		14	14						16

Pipe-Ø	Axle-Ø	EL=	IG	S	F	G	AG	BG
16x1	6	RL+			3	3	13	
	6	RL+			5	5	15	
	8	RL+			5	5	18	
	10	RL+	6	5	5	5	15	5

\* - To determine the load bearing capacity of the axles and pipes, please use the chart on page 3.

Other designs upon request.

- - Design upon request
- - In the standard

Ordering example

ST-001N-20x1,5N A8F EL=372

# Gravity conveyor roller

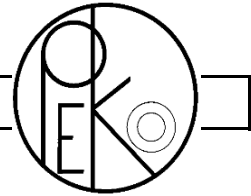

## ST-003 / ST-003N

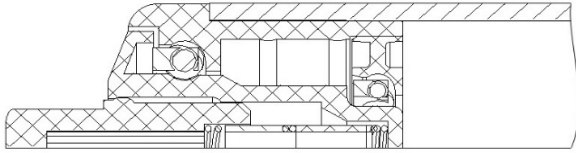

Conveyor roller bearings made of thermoplastic material with two rows of balls. The balls are available in steel (ST-003) or in stainless steel W-Nr 1.4034 (ST-003N). Stub axle of plastic, spring-loaded.

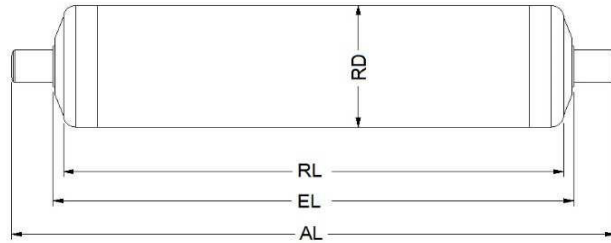

Pipe-Ø	Axle-Ø	Pipe design								Maximum load bearing capacity per roller*													
		S	SV	SG	SP	N	PG	PB	ALU	003	003N												
20x1,5	6	●	●			●	●	●	●	8	8												16
30x1,8	8						●	●		10	10												16
40x2,3	8,10						●	●		10	10												16
50x2,8	8,10						●	●		20	20												16

Pipe-Ø	Axle-Ø	EL=	IG	S	F	G	AG	BG
	6	RL+						
	8	RL+			6			
					6			

\* - To determine the load bearing capacity of the axles and pipes, please use the chart on page 3.

Other designs upon request.

- - Design upon request
- - In the standard

Ordering example

ST-003N-20x1,5PB A6FF EL=372

# Gravity conveyor roller

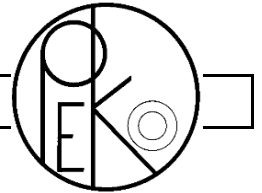

ST-005

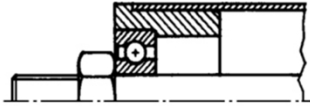

Conveyor roller bearings of thermoplastic material with grooved ball bearing 608 ZZ (ST-005). The ball bearing is available for wet operation also as RS (ST-005RS) or INOX (ST-005RSN).

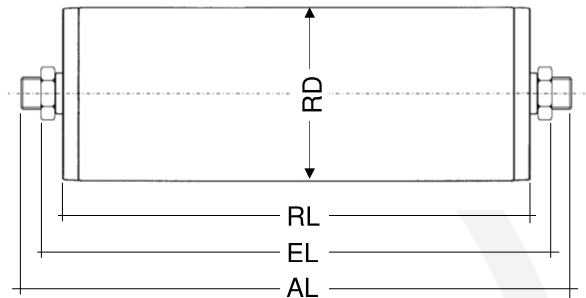

Pipe-Ø	Axle-Ø	Pipe design								Maximum load bearing capacity per roller*												
		S	SV	SG	SP	N	PG	PB	ALU	005												
30x1	8,10	●	●	○	●	●				60												
30x1,8	8,10						●	●		60												
32x2	8,10	●	●	○	●	●				60												

Pipe-Ø	Axle-Ø	EL=	Internal thread IG	Spanner flat S	Spring axle F	Smooth G	External thread AG	Deposited external thread BG	
	8	RL+					14		6
	10	RL+	10						

\* - To determine the load bearing capacity of the axles and pipes, please use the chart on page 3.

Other designs upon request.

- - Design upon request
- - In the standard

Ordering example	ST-005-30x1SV A8 AG8x10, EL=372
------------------	---------------------------------

# Gravity conveyor roller

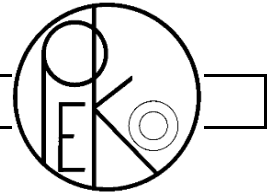

ST-007

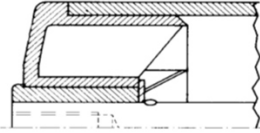

Friction bearings of thermoplastic material.

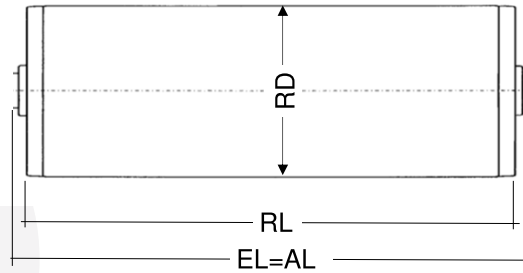

Pipe-Ø	Axle-Ø	Pipe design								Maximum load bearing capacity per roller*												
		S	SV	SG	SP	N	PG	PB	ALU	007												
30x1	12	●	●	○	●	●					20											6
50x1,5	8,10,12,14	●	●	○	●	●				●	20											8
50x2,8	8,10,12,14									●	20											8
60x1,5	8,10,12,14	●	●	○	●						20											10
60x2	8,10,12,14	●	●	○	●						20											10
60,3x1,65	8,10,12,14					●					20											10
63x3	8,10,12,14									●	20											10

Pipe-Ø	Axle-Ø	EL=	Internal thread IG	Spanner flat S	Spring axle F	Smooth G	External thread AG	Deposited external thread BG
8	RL+				7	7	21	
10	RL+	10		7	7	7	18	10
12	RL+	10		7	7	7	20	10
14	RL+	10		7	7	7	22	10

\* - To determine the load bearing capacity of the axles and pipes, please use the chart on page 3.

Other designs upon request.

- - Design upon request
- - In the standard

Ordering example

ST-007-30x1SV A12 IG8x12 EL=372

# Gravity conveyor roller

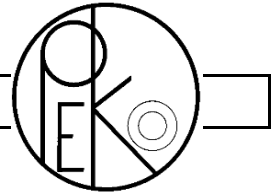

## ST-009 / ST-009N

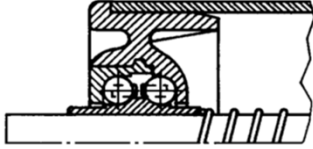

Conveyor roller bearings of thermoplastic material with two rows of balls. The balls are available in steel (ST-009) or in Niro W no. 1.4034 (ST-009N).

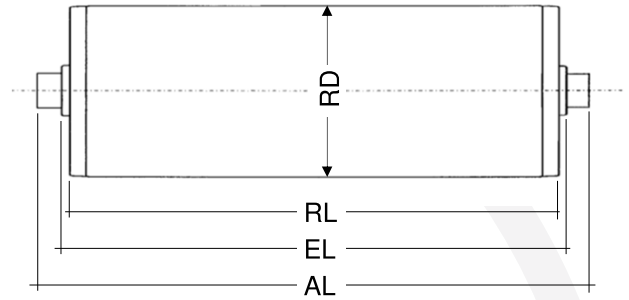

Pipe-Ø	Axle-Ø	Pipe design								Maximum load bearing capacity per roller*												
		S	SV	SG	SP	N	PG	PB	ALU	600	N600											
50x1,5	8,10,SK11,12	●	●	○	●	●			●	30	30											7
50x2,8	8,10,SK11,12						●	●		30	30											7
60x1,5	8,10,SK11,12	●	●	○	●					30	30											10
60,3x1,65	8,10,SK11,12					●				30	30											10
63x3	8,10,SK11,12							●	●	30	30											10

Pipe-Ø	Axle-Ø	EL=	Internal thread IG	Spanner flat S	Spring axle F	Smooth G	External thread AG	Deposited external thread BG
	8	RL+						
	10	RL+	8	7	7	7	21	
	SK11	RL+						8
	12	RL+	8	7	7	7	20	8

\*- To determine the load bearing capacity of the axles and pipes, please use the chart on page 3.

Other designs upon request.

- - Design upon request
- - In the standard

Ordering example

ST-009-50x1,5N AN8 F EL=372

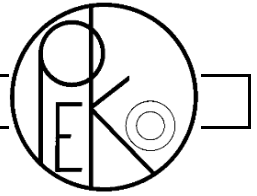

# Gravity conveyor roller

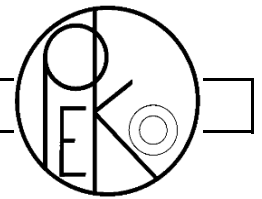

ST-013

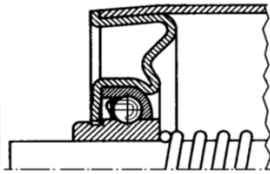

Conveyor roller bearings of galvanised sheet steel with cone ball bearings. Ball cage of plastic.

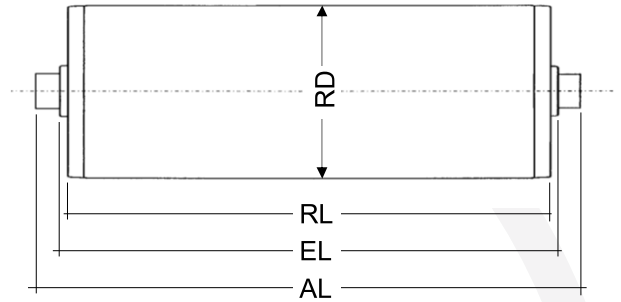

Pipe-Ø	Axle-Ø	Pipe design								Maximum load bearing capacity per roller*												
		S	SV	SG	SP	N	PG	PB	ALU	013												
30x1,5	8,10	●	●	○	●						60											2
40x1,5	8,10,SK11,12	●	●	○	●						160											2
48x1,5	8,10,SK11,12	●	●	○							160											2
50x1,5	8,10,SK11,12	●	●	○	●						160											2
50x2	8,10,SK11,12	●	●	○	●						160											2
60x1,5	8,10,SK11,12	●	●	○	●						160											2
60x2	10,SK11,12	●	●	○	●						160											2
80x2	10,SK11,12	●	●	○	●						160											2

Pipe-Ø	Axle-Ø	EL=	IG	S	F	G	AG	BG
	8	RL+			6	6	20	
	10	RL+	10	6	6	6	17	7
	SK11	RL+			6	6		
	12	RL+	10	6	6	6	19	7
80x2	10	RL+	12	12	12	12	22	12
	SK11	RL+			12	12		
	12	RL+	12	12	12	12	24	12

\* - To determine the load bearing capacity of the axles and pipes, please use the chart on page 3.

Other designs upon request.

- - Design upon request
- - In the standard

Ordering example

ST-013-40x1,5SV ASK11 F EL=372

# Gravity conveyor roller

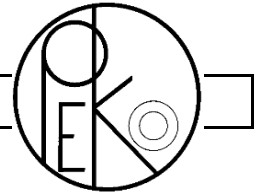

ST-017

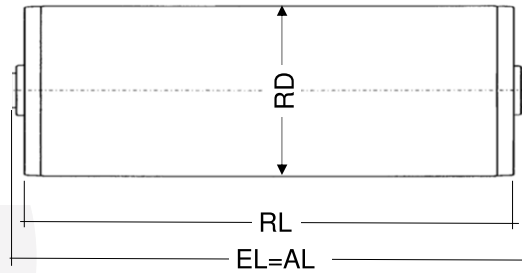
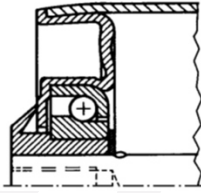

Conveyor roller bearings of galvanized sheet cone ball bearings.

Pipe-Ø	Axle-Ø	Pipe design								Maximum load bearing capacity per roller*												
		S	SV	SG	SP	N	PG	PB	ALU	017												
50x1,5	10,SK11,12	●	●	○	●					240												3
50x2	10,SK11,12	●	●	○	●					240												3
50x3	10,SK11,12	●	●	○	●					240												3
60x1,5	10,SK11,12	●	●	○	●					240												3
60x2	10,SK11,12	●	●	○	●					240												3
80x2	10,SK11,12	●	●	○	●					240												3

Pipe-Ø	Axle-Ø	EL=	Internal thread IG	Spanner flat S	Spring axle F	Smooth G	External thread AG	Deposited external thread BG
	10	RL+	10	10	9	9	19	
	SK11	RL+			9	9		
	12	RL+	10	10	9	9	21	10
80x2	10	RL+	9	7	7	7	19	
	SK11	RL+			7	7		
	12	RL+	9	7	7	7	21	9

\* - To determine the load bearing capacity of the axles and pipes, please use the chart on page 3.

Other designs upon request.

- - Design upon request
- - In the standard

Ordering example	ST-017-50x1,5SV A12 IG8x15 EL=372
------------------	-----------------------------------

# Gravity conveyor roller

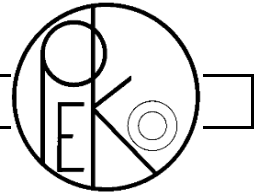

ST-018

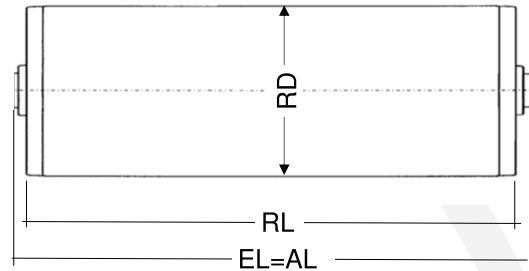
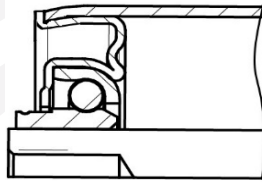

Conveyor roller bearings of galvanised sheet steel with cone ball bearings also for use in high or low temperatures.  
+240°C / -40°C

Pipe-Ø	Axle-Ø	Pipe design								Maximum load bearing capacity per roller*													
		S	SV	SG	SP	N	PG	PB	ALU	Ø18													
50x1,5	10,SK11,12,14,15	●	●	○	●					240													3
50x2	10,SK11,12,14,15	●	●	○	●					240													3
60x1,5	10,SK11,12,14,15	●	●	○	●					240													3
60x2	10,SK11,12,14,15	●	●	○	●					240													3
80x2	10,SK11,12,14,15	●	●	○	●					240													3

Pipe-Ø	Axle-Ø	EL=							
			IG	S	F	G	AG	BG	
	10	RL+	10	6	6	6	17		
	SK11	RL+			6	6			
	12	RL+	10	6	6	6	19	6	
	14	RL+	10	6	6	6	21	6	
	15	RL+	10	6	6	6		6	
80x2	10	RL+	6	7	7	7	19		
	SK11	RL+			7	7			
	12	RL+	6	7	7	7	21	9	
	14	RL+	6	7	7	7	23	9	
	15	RL+	6	7	7	7		9	

\* - To determine the load bearing capacity of the axles and pipes, please use the chart on page 3.

Other designs upon request.

- - Design upon request
- - In the standard

Ordering example

ST-018-50x1,5SV A15 BG12x10 EL=372

# Gravity conveyor roller

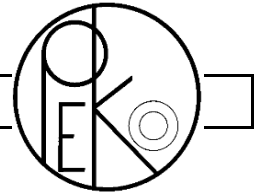

## ST-021 / ST-021N

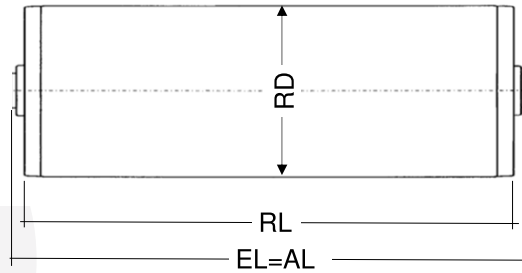
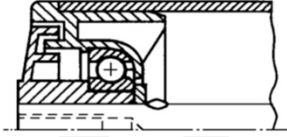

Conveyor roller bearings of thermoplastic material with labyrinth seal and cone ball bearings. The balls are available in steel /ST-021) or Niro W-no.1.4301 (ST-021N).

Pipe-Ø	Axle-Ø	Pipe design								Maximum load bearing capacity per roller*												
		S	SV	SG	SP	N	PG	PB	ALU	021	021N											
50x1,5	10,SK11,12,14,15	●	●	○	●	●			●	160	50											10
50x2	10,SK11,12,14,15	●	●	○	●	●				160	50											10
50x2,8	10,SK11,12,14,15						●	●		160	50											10
60x1,5	10,SK11,12,14,15	●	●	○	●					160	50											10
60x2	10,SK11,12,14,15	●	●	○	●					160	50											10
60,3x1,65	10,SK11,12,14,15					●				160	50											10
63x3	10,SK11,12,14,15						●	●		160	50											10
63,5x2,9	10,SK11,12,14,15	●	●	○						160	50											10
80x2	10,SK11,12,14,15	●	●	○	●	●				160	50											10

Pipe-Ø	Axle-Ø	EL=	Internal thread IG	Spanner flat S	Spring axle F	Smooth G	External thread AG	Deposited external thread BG
	10	RL+	7	6	6	6	17	7
	SK11	RL+			6	6		
	12	RL+	7	6	6	6	19	7
	14	RL+	7	6		6	21	7
	15	RL+	7	6		6		7

\* - To determine the load bearing capacity of the axles and pipes, please use the chart on page 3.

Other designs upon request.

- - Design upon request
- - In the standard

Ordering example

ST-021-63x3PG A12 AG12x15, EL=372

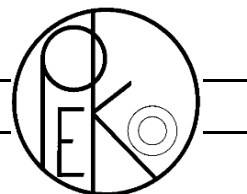

# Gravity conveyor roller

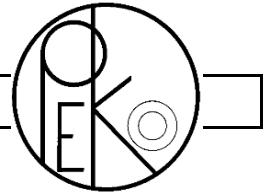

ST-024

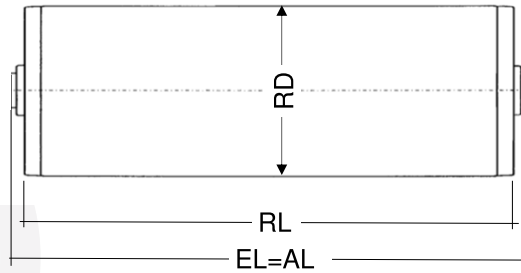
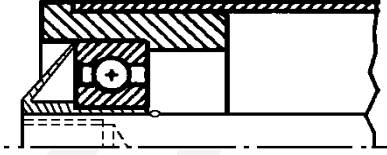

Conveyor roller bearings of thermoplastic material with grooved ball bearing 6202. The ball bearing is also available as ZZ (ST-024Z), as RS (ST-024RS) or INOX (ST-024RSN).

Pipe-Ø	Axle-Ø	Pipe design								Maximum load bearing capacity per roller*									
		S	SV	SG	SP	N	PG	PB	ALU	024									
40x1,5	8,10,SK11,12,14,15	●	●	○	●	●					220								8

Pipe-Ø	Axle-Ø	EL=	Internal thread IG	Spanner flat S	Spring axle F	Smooth G	External thread AG	Deposited external thread BG
	8	RL+			11	11	23	
	10	RL+	11	11	11	11	20	11
	SK11	RL+			11	11		
	12	RL+	11	11	11	11	22	11
	14	RL+	11	11	11	11	24	11
	15	RL+	11	11	11	11		11

\* - To determine the load bearing capacity of the axles and pipes, please use the chart on page 3.\*

Other designs upon request.

- - Design upon request
- - In the standard

Ordering example	ST-024-40x1,5 SV A10 F EL=372
------------------	-------------------------------

# Gravity conveyor roller

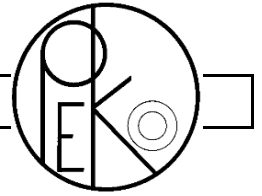

## ST-025

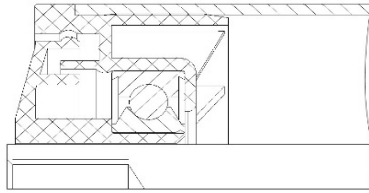

Conveyor roller bearings of thermoplastic material with grooved ball bearing 6002 (ST-025) and labyrinth seal. The ball bearing is also available as 2RS (ST-025RS), INOX (ST-025RSN) or Delrin (ST-025D).

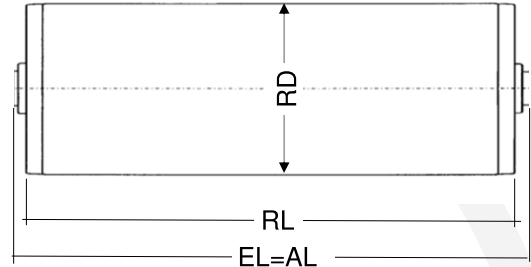

Pipe-Ø	Axle Ø	Pipe design								Maximum load bearing capacity per roller*													
		S	SV	SG	SP	N	PG	PB	ALU	025	025D												
40x1,5	8,10,SK11,12,14	●	●	○	●	●					160												13
50x1,5	8,10,SK11,12,14,15	●	●	○	●	●			●		160	40											10
50x2	8,10,SK11,12,14,15	●	●	○	●	●					160	40											10
50x2,8	8,10,SK11,12,14,15						●	●			160	40											10
60x1,5	8,10,SK11,12,14,15	●	●	○	●						160	40											10
60x2	8,10,SK11,12,14,15	●	●	○	●						160	40											10
60,3x1,65	8,10,SK11,12,14,15					●					160	40											10
63x3	8,10,SK11,12,14,15						●	●			160	40											10
63,5x2,9	8,10,SK11,12,14,15	●	●	○							160	40											10
80x2	10,SK11,12,14,15	●	●	○	●	●					160	40											10
88,9x2,9	10,SK11,12,14,15	●	●	○	●	●					160	40											10

Pipe-Ø	Axle-Ø	EL=	IG	S	F	G	AG	BG
40x1.5		RL+	6	6	5	5	**	6
60-63.5		RL+	6	6	6	6	***	6
	8	RL+	6	6	5	5	19	
	10	RL+	6	6	5	5	16	6
	SK11	RL+			5	5		
	12	RL+	6	6	5	5	18	6
	14	RL+	6	6		5	20	6
	15 Laby lose	RL+	6	6				6

\* - To determine the load bearing capacity of the axles and pipes, please use the chart on page 3.

\*\* A10=16 / A12=17 / A14=20

\*\*\* A8=19 / A10=16 / A12=18 / A14=20

Other designs upon request.

○ -Design upon request

● -In the standard

Ordering example

ST-025-50x1,5 ALU AN12 IG8x15, EL=372



# Gravity conveyor roller

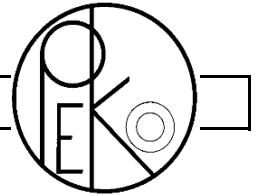



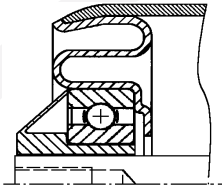

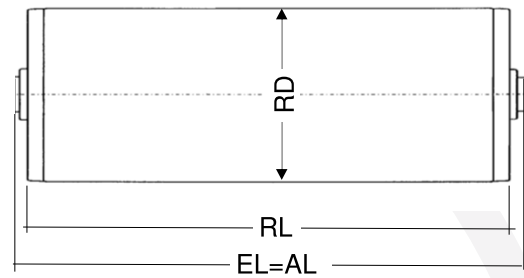

## ST-028



Conveyor roller bearings of galvanised sheet steel with grooved ball bearing 6202/6003 (ST-028). The ball bearing is also available as ZZ (ST-028Z) or 2RS (ST-028RS).

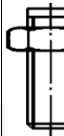

Pipe-Ø	Axle-Ø	Pipe design								Maximum load bearing capacity per					
		S	SV	SG	SP	N	PG	PB	ALU	028					
50x2	10,SK11,12,14,15,17	●	●	○	●					240					2
60x2	10,SK11,12,14,15,17	●	●	○	●					240					3
63,5x2,9	10,SK11,12,14,15,17	●	●	○						240					3
70x2	10,SK11,12,14,15,17	●	●	○						240					3

Pipe-Ø	Axle-Ø	EL=						
			IG	S	F	G	AG	BG
10 SK11	10	RL+	16	15	15	15	25	16
	12	RL+	16	15	15	15	27	16
	14	RL+	16	15	15	15	29	16
	15	RL+	16	15	15	15		16
	17	RL+	16	15	15	15		16

\* - To determine the load bearing capacity of the axles and pipes, please use the chart on page 3.

Other designs upon request.

- - Design upon request
- - In the standard

Ordering example

ST-028-70x2 SV A14 S10x10 EL=372

# Gravity conveyor roller

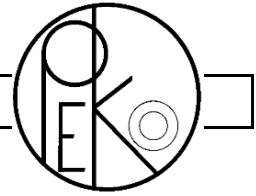

ST-029

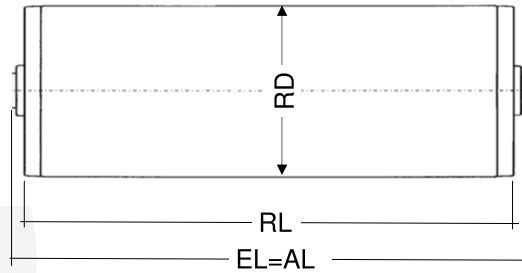
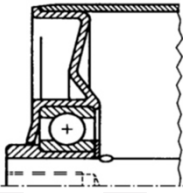

Conveyor roller bearings of galvanised sheet steel with grooved ball bearing 6202/6003 (ST-029). The ball bearing is also available as ZZ (ST-029Z) or 2RS (ST-029RS).

Pipe-Ø	Axle-Ø	Pipe design								Maximum load bearing capacity per roller*														
		S	SV	SG	SP	N	PG	PB	ALU	20	25	30	35	40	45	50	55	60	65	70	75	80		
50x1,5	10,SK11,12,14,15,17	●	●	○	●	●				240														3
50x2	10,SK11,12,14,15,17	●	●	○	●	●				240														3
60x1.5	10,SK11,12,14,15,17	●	●	○	●					240														4
60.3x1.65	10,SK11,12,14,15,17					●				240														4
60x2	10,SK11,12,14,15,17	●	●	○	●					240														4
60x3	10,SK11,12,14,15,17	●	●	○	●					240														4
63.5x2.9	10,SK11,12,14,15	●	●	○	●					240														4
70x2	10,SK11,12,14,15,17	●	●	○						240														4
80x2	10,SK11,12,14,15,17	●	●	○	●					240														3
80x3	10,SK11,12,14,15,17	●	●	○	●					240														3

Pipe-Ø	Axle-Ø	EL=							
			IG		F	G	AG	BG	
	10	RL+	11	10	10	10	20	10	
	SK11	RL+			10	10			
	12	RL+	11	10	10	10	22	10	
	14	RL+	11	10		10	22	10	
	15	RL+	11	10		0		10	
	17	RL+	11	10		0		10	
80	12,14	RL+	9	9	7	7		9	

\* - To determine the load bearing capacity of the axles and pipes, please use the chart on page 3.

Other designs upon request.

- -Design upon request
- -In the standard

Ordering example

ST-029-60x2 SV A15 S12x15, EL=372



# Gravity conveyor roller

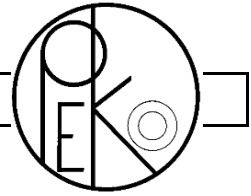

ST-031

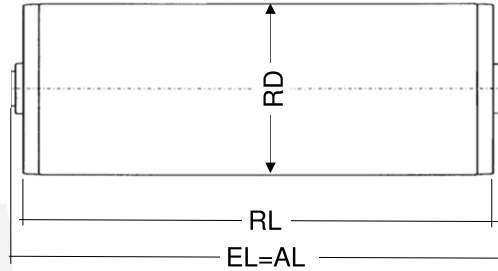
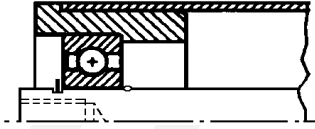

Conveyor roller bearings of thermoplastic material with grooved ball bearing 6004 ZZ (ST-031). The ball bearing is for wet operation and is also available as RS (ST-031RS) or INOX (ST-031RSN).

Pipe-Ø	Axle-Ø	Pipe design								Maximum load bearing capacity per roller*												
		S	SV	SG	SP	N	PG	PB	ALU	Ø31												
50x1,5	20	●	●	○	●	●					360											10
50x2	20	●	●	○	●	●					360											10
60x1,5	20	●	●	○	●	●					360											10
60x2	20	●	●	○	●	●					360											10

Pipe-Ø	Axle-Ø	EL=	Internal thread IG	Spanner flat S	Spring axle F	Smooth G	External thread AG	Deposited external thread BG
20	20	RL+	10	10			26	10

\* - To determine the load bearing capacity of the axles and pipes, please use the chart on page 3.

Other designs upon request.

- - Design upon request
- - In the standard

Ordering example	ST-031-50x2 S A20 S14x13, EL=372
------------------	----------------------------------

# Gravity conveyor roller

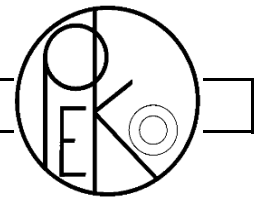

ST-033

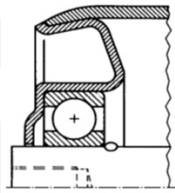

Conveyor roller bearings of uncoated or galvanised sheet steel with grooved ball bearing 6204/6004 with axle 20 or 6205/6005 with axle 25. The ball bearing is also available as ZZ (ST-033Z) or 2RS (ST-033RS).

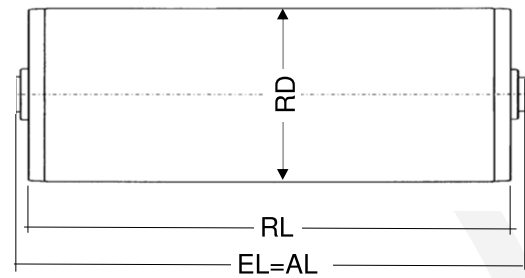

Pipe-Ø	Axle-Ø	Pipe design								Maximum load bearing capacity per roller*					
		S	SV	SG	SP	N	PG	PB	ALU	033					
63,5x2,9	17	●	●	○						360					4
63,5x2,9	20	●	●	○						400					4
80x2	17,20,25	●	●	○	●	●				500					5
80x3	17,20,25	●	●	○	●					500					5
88,9x2,9	17,20,25	●	●	○	●	●				500					5
108x3,6	17,20,25	●	●	○						500					6

Pipe-Ø	Axle-Ø	EL=	IG	S	F	G	AG	BG
	17	RL+	10	10				10
	20	RL+	10	10			26	10
	25	RL+	10	10				10

\* - To determine the load bearing capacity of the axles and pipes, please use the chart on page 3.

Other designs upon request.

- - Design upon request
- - In the standard

Ordering example

ST-033-88,9 x2,9 SV A20 IG12x18, EL=372

# Gravity conveyor roller

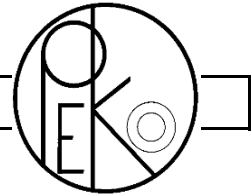

ST-034

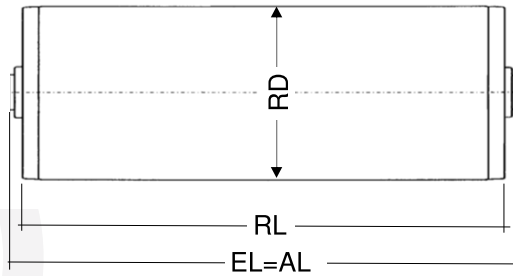
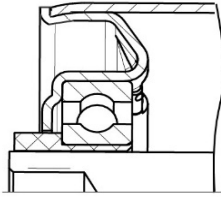

Conveyor roller bearings of uncoated or galvanised sheet steel with grooved ball bearing 6004/6204 with axle 20 or 6205 with axle 25.  
The ball bearing is also available as ZZ (ST-034Z) or 2RS (ST-034RS).

Pipe-Ø	Axle-Ø	Pipe design								Maximum load bearing capacity per roller*					
		S	SV	SG	SP	N	PG	PB	ALU	034					
63,5x2,9	20	●	●	○						400					4
80x2	SK14,17,20	●	●	○	●	●				500					5
80x3	SK14,17,20	●	●	○	●					500					5
88,9x2,9	SK14,17,20,25	●	●	○	●	●				500					5
108x3,6	SK14,17,20,25	●	●	○						500					6

Pipe-Ø	Axle- Ø	EL=	Internal thread IG	Spanner flat S	Spring axle F	Smooth G	External thread AG	Deposed external thread BG
	SK14	RL+			10	10		
	17	RL+	11	11				11
	20	RL+	11	11			32	11
	25	RL+	11	11				11

\* - To determine the load bearing capacity of the axles and pipes, please use the chart on page 3.

Other designs upon request.

- - Design upon request
- - In the standard

Ordering example

ST-034-88,9 x2,9 SV A20 IG12x18, EL=372

# Gravity conveyor roller

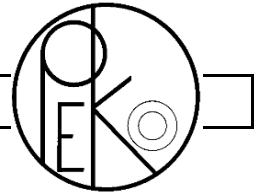

ST-037

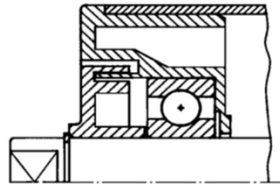

Conveyor roller bearings of thermoplastic material with grooved ball bearing 6204 (ST-037). The ball bearing is also available as ZZ (ST-037Z) or 2RS (ST-037RS).

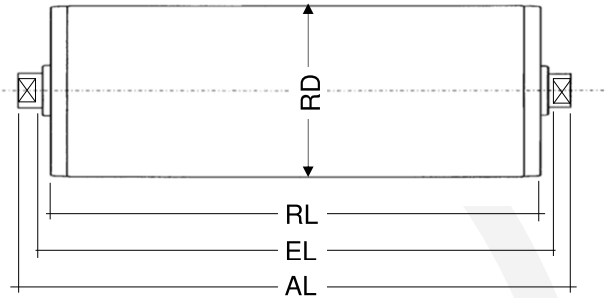

Pipe-Ø	Axle-Ø	Pipe design								Maximum load bearing capacity per roller*													
		S	SV	SG	SP	N	PG	PB	ALU	037													
60x2	17,20	●	●	○	●						360												10
63,5x2,9	17,20	●	●	○							360												10
80x2	17,20	●	●	○	●	●					360												10
88,8x2,9	17,20	●	●	○		●					360												10

Pipe-Ø	Axle-Ø	EL=	Internal thread IG	Spanner flat S	Spring axle F	Smooth G	External thread AG	Deposited external thread BG
	17	RL+	12	11				12
	20	RL+	7	6			27	7

\* - To determine the load bearing capacity of the axles and pipes, please use the chart on page 3.

Other designs upon request.

- - Design upon request
- - In the standard

Ordering example

ST-037-88,9 x2,9 SV A20 S 15x13 EL=372

# Gravity conveyor roller

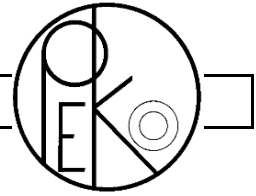

## ST-040

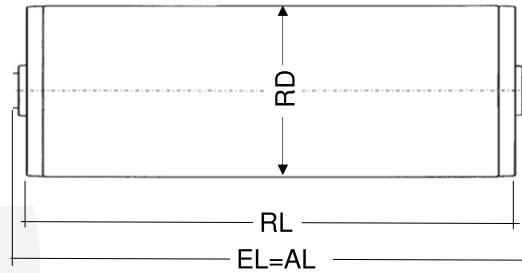
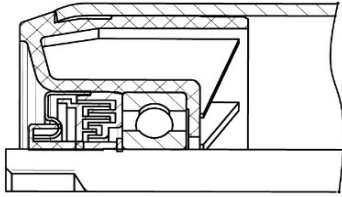

Conveyor roller bearings of thermoplastic material with grooved ball bearing 6204ZZ (ST-040Z) and labyrinth seal. The ball bearing is also available as RS (ST-040RS) or INOX (ST-040RSN).

Pipe-Ø	Axle-Ø	Pipe design								Maximum load bearing capacity per roller*										
		S	SV	SG	SP	N	PG	PB	ALU	Ø40										
88,9x2,9	20	●	●	○	●	●				300										16
108x3,6	20	●	●	○						300										16

Pipe-Ø	Axle-Ø	EL=	Internal thread IG	Spanner flat S	Spring axle F	Smooth G	External thread AG	Deposited external thread BG
	20	RL+	10	10			26	10

\* - To determine the load bearing capacity of the axles and pipes, please use the chart on page 3.

Other designs upon request.

- - Design upon request
- - In the standard

Ordering example	ST-040-88,9 x2,9 SV A20 IG12x18, EL=372
------------------	---





# Gravity conveyor roller

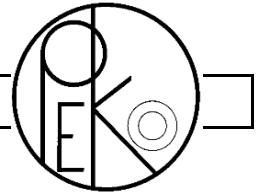

## ST-045

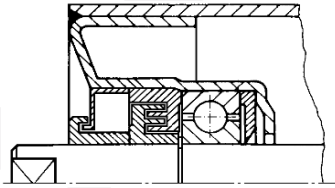

Conveyor roller bearings of uncoated sheet steel welded in the pipe with grooved ball bearing 6204 with axle 20 or 6305 with axle 25. The ball bearing is also available as 2RS (ST-045RS).

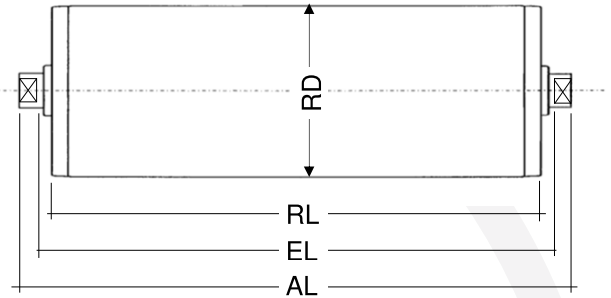

Pipe-Ø	Axle -Ø	Pipe design								Ø45	Maximum load bearing capacity per roller*												
		S	SV	SG	SP	N	PG	PB	ALU														
63,5x2,9	20	●	●	○						560													10
80x2	20	●	●	○	●					560													10
80x3	20	●	●	○	●					560													10
88,9x2,9	20,25	●	●	○	●					560													10
108x3,6	20,25	●	●	○						560													10
133x4	20,25	●	●	○						560													10

Pipe-Ø	Axle- Ø	EL=	IG	S	F	G	AG	BG
63,5x2,9	20	RL+	10	10			30	10
	20	RL+	10	6			26	6
	25	RL+	10	6				6

\* - To determine the load bearing capacity of the axles and pipes, please use the chart on page 3.

Other designs upon request.

- - Design upon request
- - In the standard

Ordering example

ST-045-133x4 SV A20 S14x13 EL=1400

# Gravity conveyor roller

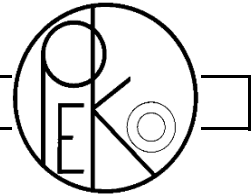

## ST-046

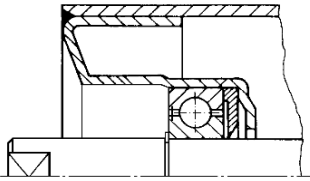

Conveyor roller bearings of uncoated sheet steel welded in pipe with grooved ball bearing 6204 ZZ with axle 20 or 6305 with axle 25. The ball bearing is also available as 2RS (ST-046RS). From axles 25, also available as NIRO stock. (ST-046N)

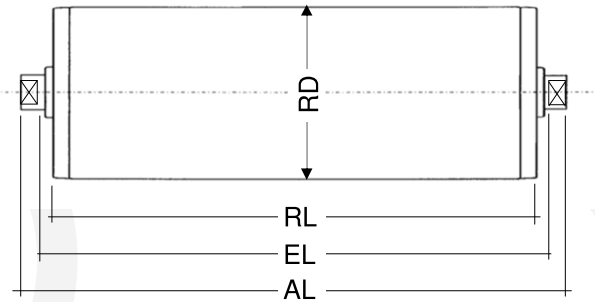

Pipe-Ø	Axle-Ø	Pipe design								Maximum load bearing capacity per roller*												
		S	SV	SG	SP	N	PG	PB	ALU	046												
63,5x2,9	20	●	●	○						560												10
80x2	20	●	●	○	●					560												10
80x3	20	●	●	○	●					560												10
88,9x2,9	20,25	●	●	○	●					560												10
108x3,6	20,25	●	●	○						560												10
133x4	20'25	●	●	○						560												10

Pipe-Ø	Axle-Ø	EL=	IG	S	F	G	AG	BG
	20	RL+	6	6			24	6
	25	RL+	6	6				6

\* - To determine the load bearing capacity of the axles and pipes, please use the chart on page 3.

Other designs upon request.

- - Design upon request
- - In the standard

Ordering example

ST-046-133x4 SV A20 S14x13 EL=2200

# Gravity conveyor roller

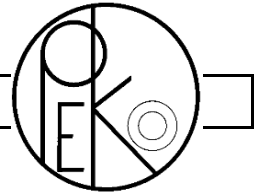

## ST-047

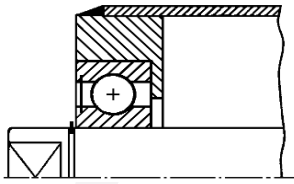

Conveyor roller bearings of steel/Niro twisted, welded in the pipe with grooved ball bearing 6204/6004 ZZ with axle 20 or 6205/6005 ZZ with axle 25. The ball bearing is also available as 2RS (ST-047RS) or as 2RS-INOX (ST-047RSN).

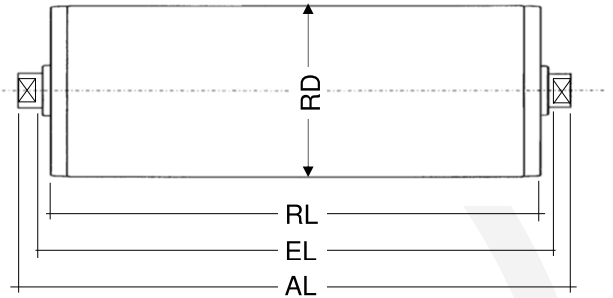

Pipe-Ø	Axle-Ø	Pipe design									Maximum load bearing capacity per roller*											
		S	SV	SG	SP	N	PG	PB	ALU	047												
63,5x2,9	20,25	●	●	○							560											10
80x2	20,25	●	●	○	●	●					560											10
80x3	20,25	●	●	○	●						560											10
88,9x2,9	20,25	●	●	○	●	●					560											10
108x3,6	20,25	●	●	○							560											10
133x4	20,25	●	●	○							560											10

Pipe-Ø	Axle-Ø	EL=	IG	S	F	G	AG	BG
	20	RL+	10	10			26	10
	25	RL+	10	10				10

\* - To determine the load bearing capacity of the axles and pipes, please use the chart on page 3.

Other designs upon request.

- - Design upon request
- - In the standard

Ordering example

ST-047-133x4 SV A20 S14x13 EL=2200

# Gravity conveyor roller

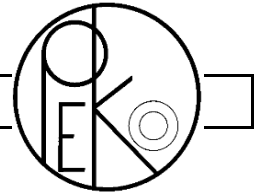

ST-049

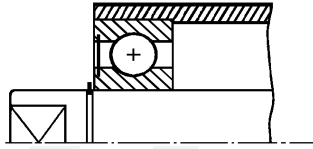

Bearing seat rotated directly in pipe with grooved ball bearing 6202/6003 ZZ or 6204/6303 ZZ and shaft locking clip.

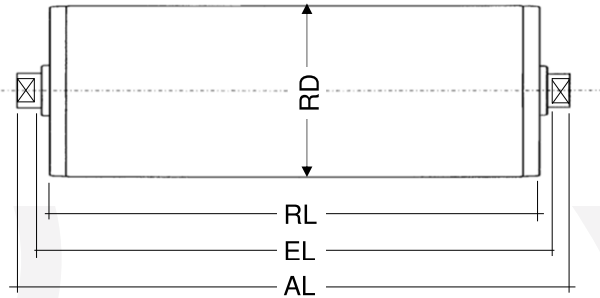

Pipe-Ø	Axle-Ø	Pipe design								Maximum load bearing capacity per roller*											
		S	SV	SG	SP	N	PG	PB	ALU	Ø											
40x3	15,17	●	●	○	●					360											0
50x2	17,20	●	●	○	●					360											0
50x3	17,20	●	●	○	●					360											0

Pipe-Ø	Axle-Ø	EL=	Internal thread	Spanner flat	Spring axle	Smooth	External thread	Deposited external thread
			IG	S	F	G	AG	BG
	15	RL+	10	10				10
	17	RL+	10	10				10
	20	RL+	10	10			26	10

\* - To determine the load bearing capacity of the axles and pipes, please use the chart on page 3.

Other designs upon request.

- - Design upon request
- - In the standard

Ordering example

ST-049-50x2 SV A20 S14x13 EL=1100

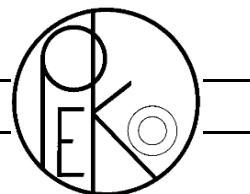

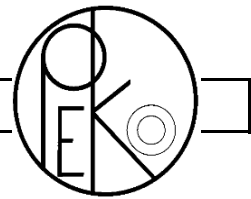

## ST-025 / ST-045

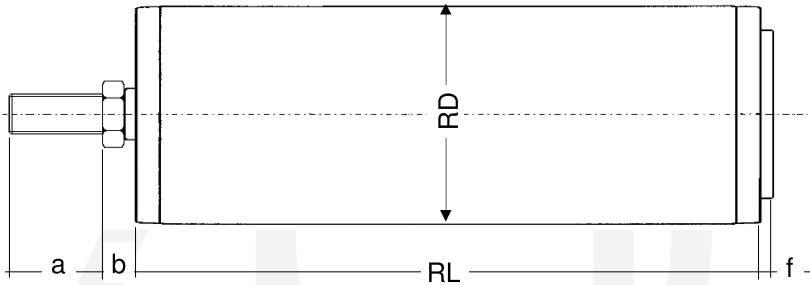

	025	045
a =	25mm	30mm
b =	10mm	15mm
f =	3mm	0mm
RL min =	60mm	92mm
RL max =	150mm	150mm

The covers for the stub roller are pressed in and also available welded with type 045. With stub rollers, the mass of EL is always given as 0.  
Please find information on bearing from the corresponding gravity conveyor roller.

Pipe-Ø	Axle-Ø	Pipe design								Maximum load bearing capacity per roller*													
		S	SV	SG	SP	N	PG	PB	ALU	025	045												
50x1,5	14	●	●	○	●	●			●	25													10
50x2	14	●	●	○	●	●				25													10
50x2,8	14						●	●		15													10
60x1,5	14	●	●	○	●					25													10
60x2	14	●	●	○	●					25													10
60,3x1,65	14					●				25													10
63x3	14						●	●		15													10
63,5x2,9	14,20	●	●	○						25	100												10
80x2	14,20	●	●	○	●	●				25	100												10
80x3	20	●	●	○	●						100												10
88,9x2,9	14,20	●	●	○	●	●				25	100												10
108x3,6	20	●	●	○							100												10
133x4	20	●	●	○							100												10

Pipe-Ø	Axle-Ø	AL=	Internal thread IG	Spanner flat S	Spring axle F	Smooth G	External thread AG	Deposited external thread BG
025	14	RL + a + b -						
045	20	RL + a + b -					1	8

\* - To determine the load bearing capacity of the axles and pipes, please use the chart on page 3.

Other designs upon request.

- - Design upon request
- - In the standard

Ordering example

ST-045-88,9x2,9 SV A20 AG20x30 RL=80  
Stub roller

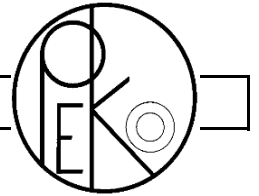

Drive and deflecting rollers are available in various designs such as steel, Niro-steel, polyurethane or fibre glass reinforced polyester. The pipe can be supplied in cylindrical, conically beveled or spherical form.

## Drive roll type 055

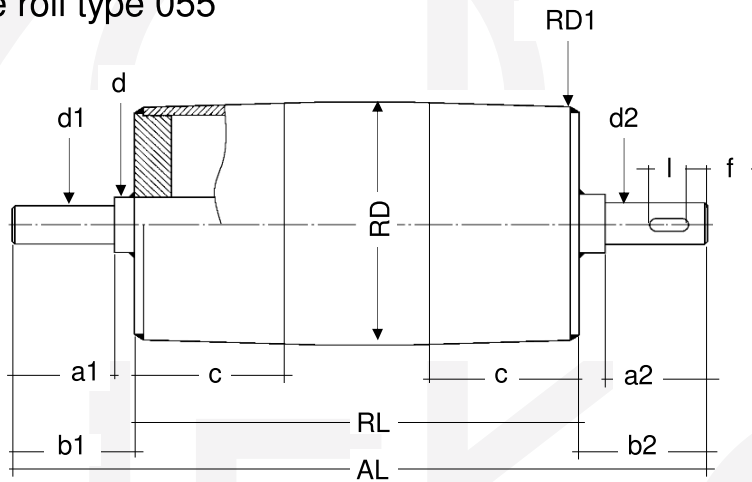

RD max = 400mm  
 RL max = 2500mm  
 AL max = 3000mm

## Deflection roll type 047

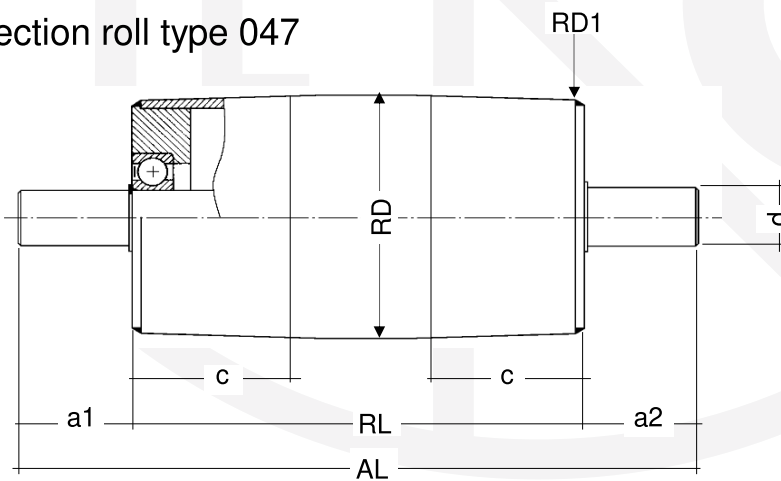

RD max = 400mm  
 RL max = 2500mm  
 AL max = 3000mm

Other designs upon request

○ - Design upon request  
 ● - In the standard

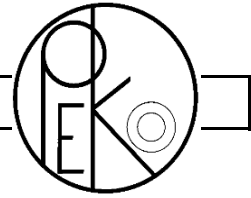

Conveyor roller with internal thread (IG)

ATS

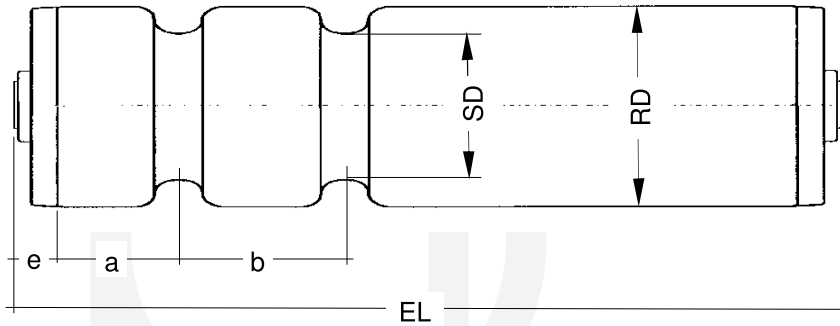

Conveyor roller with smooth axle (G) or spring axle (F)

ATS

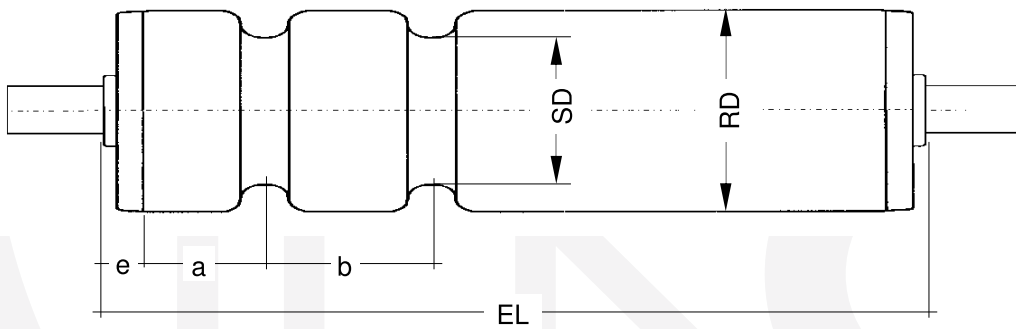

Conveyor roller with width across flats (S)

ATS

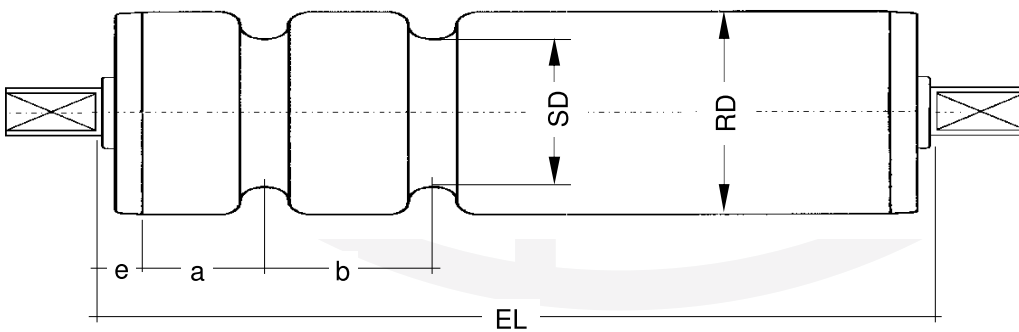

Conveyor roller with external thread (AG)

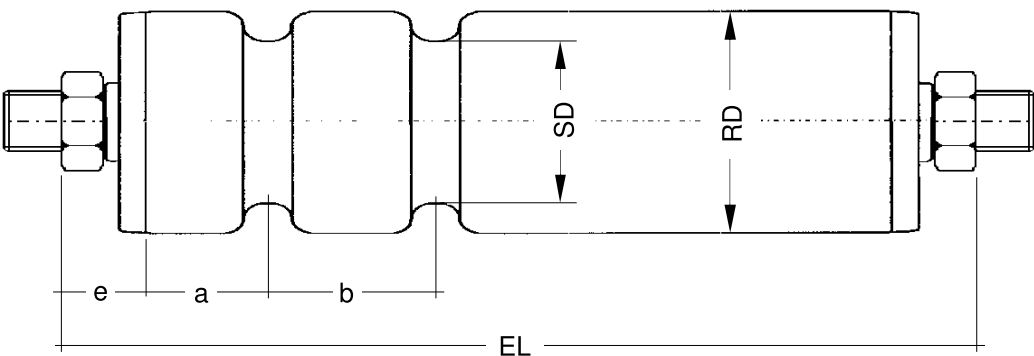

ATS

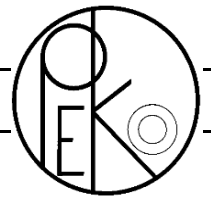

# Powered conveyor roller with belt grooves

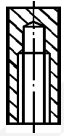
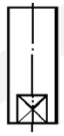

Pipe-Ø	Axle-Ø	Pipe design								Belts-Ø	Minimum				Possible bearing
		S	SV	SG	SP	N	PG	PB	ALU		a	b	a+b	SD	
30x1	8	●	●	○	●					4	30	30	60	22	005
40x1,5	8,10,SK11,12,14,15	●	●	○	●					4	30	30	90	32	024, 013
50x1,5	10,SK11,12,14,15	●	●	○	●					5	30	30	120	40	025, 013
50x1,5	10,SK11,12,14,15	●	●	○	●					6	30	30	120	38	025, 013
50x2,8	10,SK11,12,14,15					●	●			5	30	30	97	40	025
60x1,5	10,SK11,12,14,15	●	●	○	●					6	35	30	120	48	025, 013
60x2	10,SK11,12,14,15,20	●	●	○	●					6	35	30	120	48	025, 013
63x3	10,SK11,12,14,15					●	●			5	35	35	120	53	025
80x2	10,SK11,12,14,15,20	●	●	○	●					8	35	30	100	64	025, 037

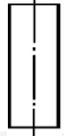
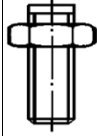
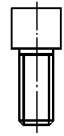
Bearing	Pipe-Ø	Axle-Ø	e =						
				IG	S	F	G	AG	BG
005		8						10	
013		8				4	4	11	
		10		6	4	4	4	9.5	
		SK11				4	4		
		12		6	4	4	4	10.5	
024		8				10.5	10.5	16.5	
		10		10.5	10.5	10.5	10.5	15	
		SK11				10.5	10.5		
		12		10.5	10.5	10.5	10.5	16	
		14		10.5	10.5		10.5	17	
025		15		10.5	10.5		10.5		
		10		8.5	8	8	8	13.5	
		SK11				8	8		
		12		8.5	8	8	8	14	
037		14		8.5	8		8	15.5	
		15		8.5	8		8		
		20		8.5	8			18.5	

## Round belt wheel of Delrin

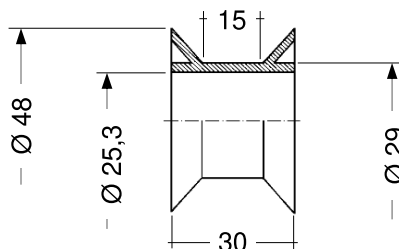

Other designs upon request.

- - Design upon request
- - In the standard

Ordering example

ATS/025-50x2,8PG A12 S8x6 EL=372  
- one-sided 2 grooves a=67, b=30, SD=40

# Powered conveyor roller with tooth belt wheel

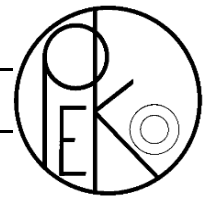

## AT1ZR PC8z20,K,Stau / AT1ZR PC8z20,K,Fest

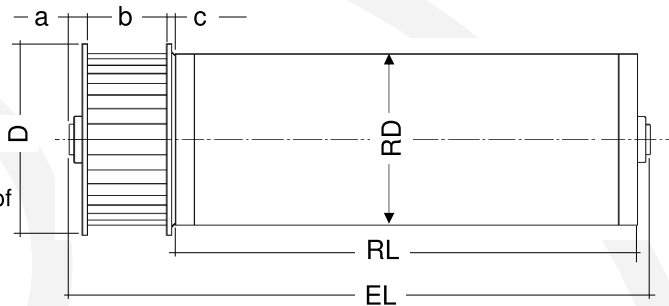
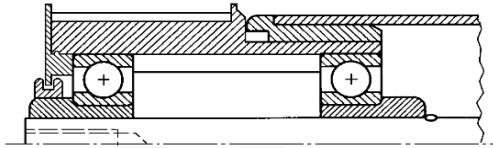

Tooth belt wheel 8 M z20 for 2 toothed belts with 12mm width of thermoplastic material as accumulation drive (Friction) or as fixed drive (fixed) with Press fit, grooved ball bearing 6202 also available as ZZ (AT1R PC8z20 Z,K), as 2RS (AT1R PC8z20 RS,K) or as INOX (AT1R PC8z20 RSN,K).

a = 10mm, b = 25,4mm, c = 4mm, D = 55mm

For information on accumulation drive, see Page 4.

**Stau = Friction**  
**Fest = Fixed**

Pipe-Ø	Axle-Ø	Pipe design								Maximum load bearing capacity per roller*						
		S	SV	SG	SP	N	PG	PB	ALU	011	013	017	021	021N	025	028
50x1,5	12,14	●	●	○	●	●			●	40	40	40	40	40	40	
50x2	12,14	●	●	○	●	●					40	40	40	40	40	40
50x2,8	12,14						●	●		40			40	40	40	
60x1,5	12,14	●	●	○	●					40	40	40	40	40	40	
60x2	12,14	●	●	○	●	●					40	40	40	40	40	40
60,3x1,65	12,14					●				40			40	40	40	
63x3	12,14						●	●		40			40	40	40	
63,5x2,9	12,14	●	●	○									40	40	40	40
80x2	12,14	●	●	○	●	●					40	40	40	40	40	

Counter-bearing			Pipe-Ø	Axle-Ø	EL=								
	Friction	Fixed				IG	S	F	G	AG	BG		
011	●	●		12	RL+	44							9
013	●	●		12	RL+	43							6
017	●	●		12,14	RL+	45							7
021/021N	●	●		12,14	RL+	43							10
025	●	●		12,14	RL+	43							10
028	●	●		12,14	RL+	48							7

\* - To determine the load bearing capacity of the axles and pipes, please use the chart on page 3.  
When using 8 M toothed belt wheels, a centre distance tolerance of +0/-0.3mm is to be maintained.

Other designs upon request.

○ - Design upon request  
● - In the standard

Ordering example

AT1ZR PC8z20,K,Fest  
025-50x1,5 SV A12 IG8x15, EL=432

# Powered conveyor roller with tooth belt wheel Poly-Chain

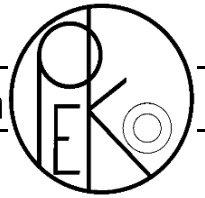

## AT2ZR PC8z20,verschweisst

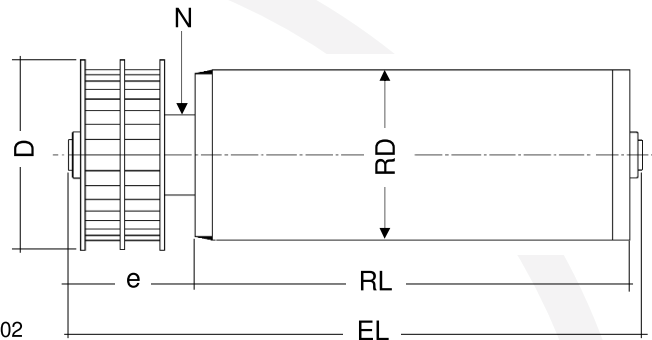
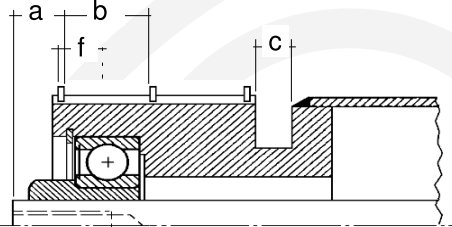

Steel/Niro - Tooth belt wheel 8 M z20 for 2 tooth belts with 12mm width welded in pipe. Available as grooved ball bearing 6202 ZZ (AT2R PC8z20) or as 2RS (AT2R PC8z20 RS).

a = 10mm, b = 12,5mm, c = 10mm, f = 1,2mm  
D = 56mm, N = 35, e = 49,4

verschweisst = welded

Pipe-Ø	Axle-Ø	Pipe design							Maximum load bearing capacity per roller*							
		S	SV	SG	SP	N	PG	PB	ALU	011	013	017	021	021N	025	028
50x1,5	12,14	●	●	○	●	●				100	100	100	100	60	100	
50x2	12,14	●	●	○	●	●					100	100	100	60	100	100
60x1,5	12,14	●	●	○	●					100	100	100	100	60	100	
60x2	12,14	●	●	○	●						100	100	100	60	100	100
60,3x1,65	12,14					●				100	100	100	100	60	100	
63,5x2,9	12,14	●	●	○								100	100	60	100	100
80x2	12,14	●	●	○	●	●					100	100	100	60	100	

Counter-bearing	Friction	Fixed	Pipe-Ø	Axle-Ø	EL=	Pipe design							
						IG	S	Spring axle	G	AG	BG		
011				12	RL+	54							9
013				12	RL+	53							6
017				12,14	RL+	55							7
021/021N				12,14	RL+	53							10
025				12,14	RL+	53							10
028				12,14	RL+	58							7

\* - To determine the load bearing capacity of the axles and pipes, please use the chart on page 3. When using 8 M toothed belt wheels, a centre distance tolerance of +0/-0.3mm is to be maintained.

Other designs upon request.

- - Design upon request
- - In the standard

Ordering example	AT2ZR PC8z20,verschweisst 025-50x1,5 SV A12 IG8x15, EL=432
------------------	---

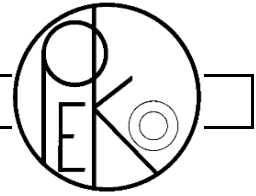

## M2R PC8z20,S / M2R PC8z20,N / M2R PC8z20,ALU

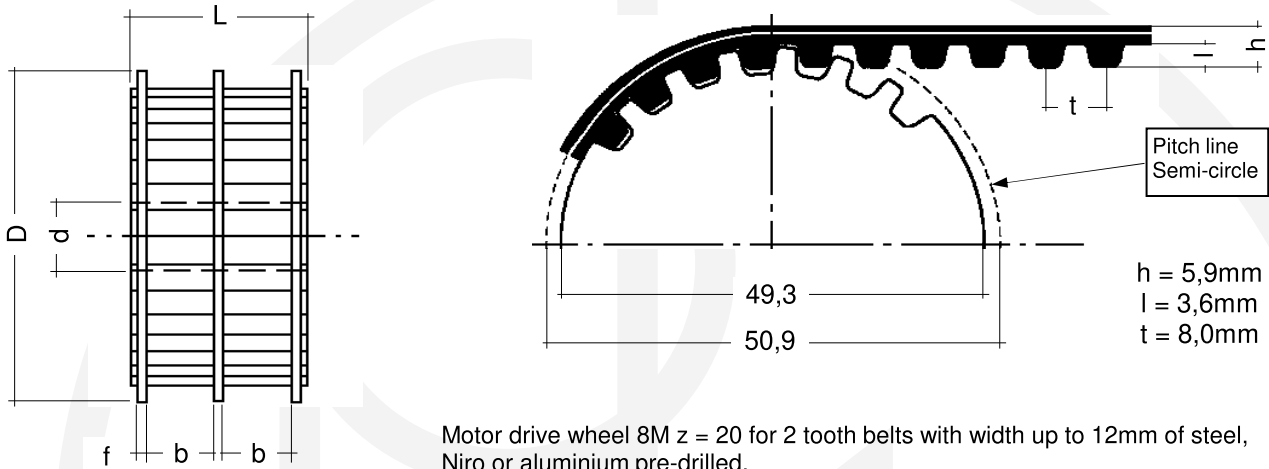

$b = 12,5\text{mm}$ ,  $f = 1,2\text{mm}$   
 $L = 32,5\text{mm}$ ,  $d = 10\text{mm}$   
 $D = 56\text{mm}$

Motor drive wheel 8M  $z = 20$  for 2 tooth belts with width up to 12mm of steel, Niro or aluminium pre-drilled.  
 The drive wheel on the motor as well as the first drive head of the roller powered by the motor drive wheel must not be made of plastic.

### Tooth belts

Order reference	Pitch	Centre distance at $z20^*$	Number of teeth	Effective	Width
ZRPCC-8M,288,b=11,2	8 mm	64 mm	36	288 mm	11,2 mm
ZRPCC-8M,352,b=11,2	8 mm	96 mm	44	352 mm	11,2 mm
ZRPCC-8M,416,b=11,2	8 mm	128 mm	52	416 mm	11,2 mm
ZRPCC-8M,456,b=11,2	8 mm	148 mm	57	456 mm	11,2 mm
ZRPCC-8M,480,b=11,2	8 mm	160 mm	60	480 mm	11,2 mm
ZRPCC-8M,544,b=11,2	8 mm	192 mm	68	544 mm	11,2 mm
ZRPCC-8M,608,b=11,2	8 mm	224 mm	76	608 mm	11,2 mm
ZRPCC-8M,640,b=11,2	8 mm	240 mm	80	640 mm	11,2 mm
ZRPCC-8M,720,b=12,0	8 mm	280 mm	90	720 mm	12,0 mm
ZRPC-8M,800,b=12,0	8 mm	320 mm	100	800 mm	12,0 mm
ZRPC-8M,896,b=12,0	8 mm	368 mm	112	896 mm	12,0 mm
ZRPC-8M,1000,b=12,0	8 mm	420 mm	125	1000 mm	12,0 mm

\* Maximum allowed centre distance tolerance  $+0/-0.3\text{mm}$ .

Other designs upon request.

Ordering example

M2R PC8z20,S  
 ZRPC-8M,352,b=11,2

# Powered accumulation conveyor roller for flat belts

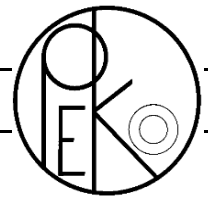

## AT1FR,KS,Stau

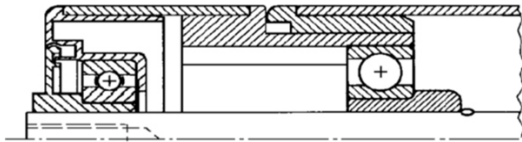

Flat belts drive head as accumulation drive.  
Grooved ball bearing 6202 also available as ZZ (AT1FR Z,KS,Stau), as 2RS (AT1FR RS,KS,Stau) or as INOX (AT1FR RS,KS,Stau).

For information on accumulation drive, see Page 4.

**Stau = Friction**

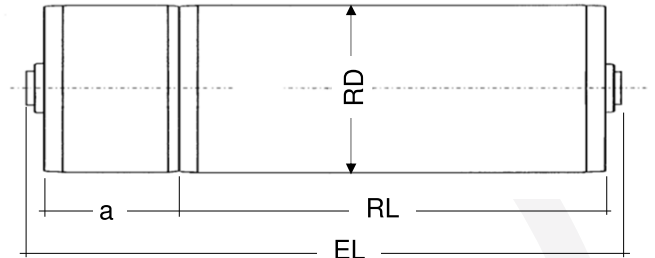

a min = 55mm

Pipe-Ø	Axle-Ø	Pipe design								025	Maximum load bearing capacity per roller*
		S	SV	SG	SP	N	PG	PB	ALU		
50x1,5	12,14	●	●	○	●	●			●	40	
50x2	12,14	●	●	○	●	●				40	
50x2,8	12,14						●	●		40	
60x1,5	12,14	●	●	○	●					40	
60x2	12,14	●	●	○	●	●				40	
60,3x1,65	12,14					●				40	
63x3	12,14						●	●		40	

Counter-bearing	Friction	Fixed	Pipe-Ø	Axle-Ø	EL=	Axle design						10
						IG	S	F	G	AG	BG	
025	●			12,14	RL+ a +	7						

\* - To determine the load bearing capacity of the axles and pipes, please use the chart on page 3.

Other designs upon request.

- - Design upon request
- - In the standard

Ordering example	AT1FR,KS,Stau 025-50x1,5 SV A12 IG8x15 EL=432 a=57
------------------	---

# Powered conveyor roller with multi-ribbed belt wheel

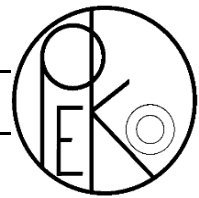

## AT1MRI,K,Fest

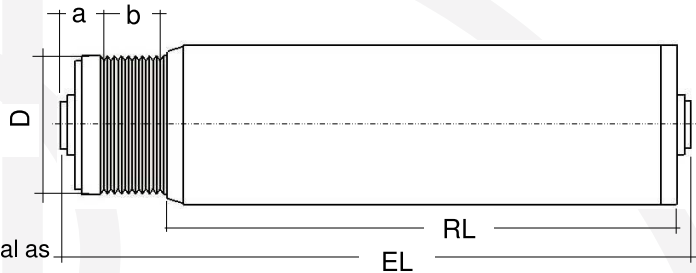
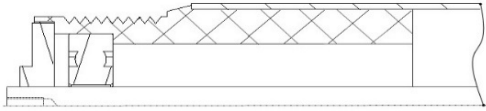

Multi-ribbed belt wheel for PJ belts of thermoplastic material as a fixed drive with press fit.  
Grooved ball bearing 6202 ZZ, available as 2RS (AT1MRI,RS,K) or as INOX (AT1MRI,RSN,K).

$a = 12\text{mm}$ ,  $b = 18.72\text{mm}$ ,  $D = 43\text{mm}$

**Fest = Fixed**

Pipe-Ø	Axle-Ø	Pipe design								Maximum load bearing capacity per roller*					
		S	SV	SG	SP	N	PG	PB	ALU	011	013	017	021	021N	025
50x1,5	12,14	●	●	○	●	●			●	40	40	40	40	40	40
50x2	12,14	●	●	○	●	●					40	40	40	40	40
50x2,8	12,14						●	●		40			40	40	40
60x1,5	12,14	●	●	○	●					40	40	40	40	40	40
60x2	12,14	●	●	○	●	●					40	40	40	40	40
60,3x1,65	12,14					●				40			40	40	40
63x3	12,14						●	●		40			40	40	40
63,5x2,9	12,14	●	●	○									40	40	40
80x2	12,14	●	●	○	●	●					40	40	40	40	40

Counter-bearing	Friction	Fixed	Pipe-Ø	Axle-Ø	EL=								
						IG	S	F	G	AG	BG		
011		●		12	RL+	37							9
013		●		12	RL+	36							6
017		●		12,14	RL+	39							7
021/021N		●		12,14	RL+	36							10
025		●		12,14	RL+	36			34.5	34.5			10

\* - To determine the load bearing capacity of the axles and pipes, please use the chart on page 3.

When using PJ belts, a centre distance tolerance of  $+2.0/-0\text{mm}$  is to be maintained.

Information on the centre distance, can be found on page 60.

Other designs upon request

- - Design upon request
- - In the standard

Ordering example

AT1MRI,K,Fest  
025-50x1,5 SV A12 IG8x15, EL=432

# Powered conveyor roller with single chain wheel

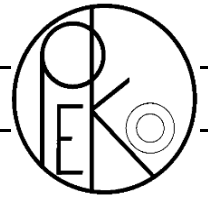

## AT1K 3/8z10,S,Stau / AT1K 3/8z10,S,Fest

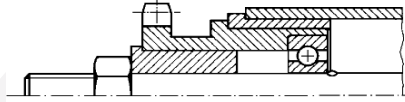

Steel chain wheel 3/8"x7/32" z10 with normal toothing as accumulation drive (Friction) or as fixed drive (Fixed) with press fit.

Grooved ball bearing 608 also available as ZZ or 2RS.

Chain wheel-side also available with IG spigot. As fixed drive not suited for stop and go.

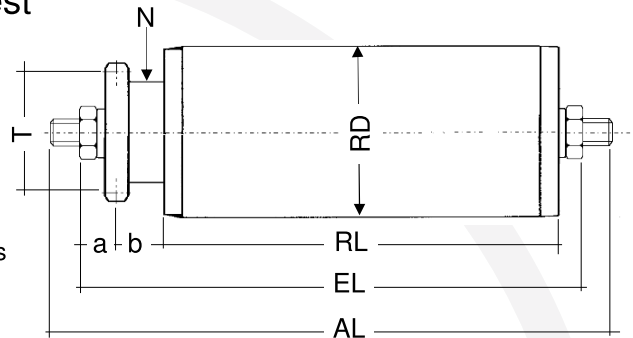

a=12mm, b=12,5mm, T=30,82mm, N=21mm

For information on accumulation drive, see Page 4.

**Stau = Friction / Fest = Fixed**

Pipe-Ø	Axle-Ø	Pipe design								Maximum load bearing capacity per roller*									
		S	SV	SG	SP	N	PG	PB	ALU	001	001N	005							
30x1	8	●	●	○	●	●				14	14	20							
30x1,8	8						●	●		14	14	20							
32x2	8	●	●	○	●	●				14	14	20							

Counter-bearing	Friction		Fixed		Pipe-Ø	Axle-Ø	EL=	Internal thread IG	Spanner flat S	Spring axle F	Smooth G	External thread AG	Deposited external thread BG	
	Friction	Fixed	Friction	Fixed										
001/001N	●	●			8	8	RL+					34		11
005					8	8	RL+					32		6

\* - To determine the load bearing capacity of the axles and pipes, please use the chart on page 3.

Other designs upon request.

- - Design upon request
- - In the standard

Ordering example	AT1K 3/8z10,S,Fest 005-30x1 SV A8 AG8x15 EL=432
------------------	--

# Powered conveyor roller with single chain wheel

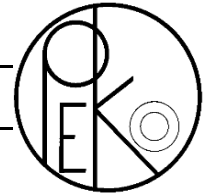

## AT1K 1/2z11,K,Stau / AT1K 1/2z11,K,Fest

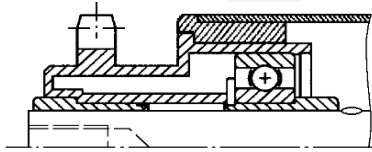

Plastic chain wheel 1/2"x5/16" z11 with rack and pinion toothing as accumulation drive (Friction) or as fixed drive (Fixed) with press fit. Grooved ball bearing 6202 also available as ZZ or 2RS. Also available with normal toothing. Not suitable for stop and go as fixed drive.

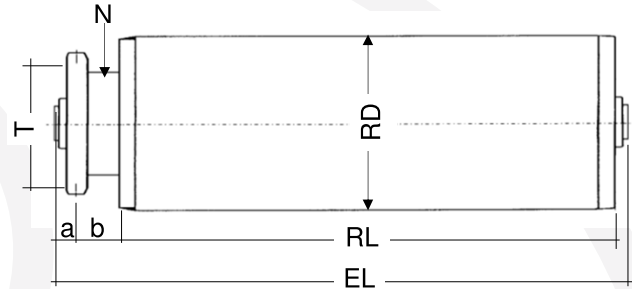

a=12mm, b=15,5mm, T=45,07mm, N=30mm

For information on accumulation drive, see Page 4.

**Stau = Friction / Fest = Fixed**

Pipe-Ø	Axle-Ø	Pipe design									Maximum load bearing capacity per roller*								
		S	SV	SG	SP	N	PG	PB	ALU	009	009N	011	013	017	021	021N	025	028	029
50x1,5	10,12,14	●	●	○	●	●			●	24	24	40	40	40	40	40	40		40
50x2	10,12,14	●	●	○	●	●						40	40	40	40	40	40	40	40
50x2,8	10,12,14						●	●		24	24	40			40	40	40		
50x3	10,12,14	●	●	○	●									40			40		
60x1,5	10,12,14	●	●	○	●					24	24	40	40	40	40	40	40		40
60x2	10,12,14	●	●	○	●	●						40	40	40	40	40	40	40	40
60,3x1,65	10,12,14					●				24	24	40			40	40	40		40
63x3	10,12,14						●	●		24	24	40			40	40	40		
63,5x2,9	10,12,14	●	●	○											40	40	40	40	40
80x2	10,12,14	●	●	○	●	●							40	40	40	40	40		40

Counter-bearing	Friction		Fixed		Pipe-Ø	Axle-Ø	EL=	Internal thread IG	Spanner flat S	Spring axle F	Smooth G	External thread AG	Deposited external thread BG	
	Friction	Fixed	Friction	Fixed										
009/009N	●	●	●	●		10,12	RL+	33						8
011	●	●	●	●		10,12	RL+	33						9
013	●	●	●	●		10,12	RL+	31						6
017	●	●	●	●		10,12,14	RL+	34						7
021/021N	●	●	●	●		10,12,14	RL+	31						10
025	●	●	●	●		10,12,14	RL+	31						10
028	●	●	●	●		10,12,14	RL+	37						7
029		●		●		10,12,14	RL+	34						7

\* - To determine the load bearing capacity of the axles and pipes, please use the chart on page 3.

Other designs upon request.

- - Design upon request
- - In the standard

Ordering example

AT1K 1/2z11,K,Fest  
025-50x1,5 SV A12 IG8x15, EL=432

# Powered conveyor roller with single chain wheel

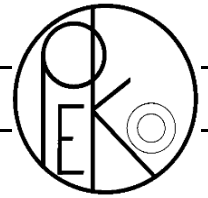

## AT1K 1/2z11,S,Stau / AT1K 1/2z11,S,Fest

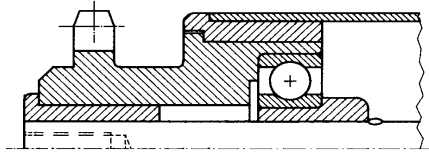

Steel chain wheel 1/2"x5/16" z11 with rack and pinion gearing as accumulation drive (Friction) or als fixed drive (Fixed) with press fit. Grooved ball bearing 6202 also available as ZZ or 2RS.

Not suitable for stop and go as fixed drive.

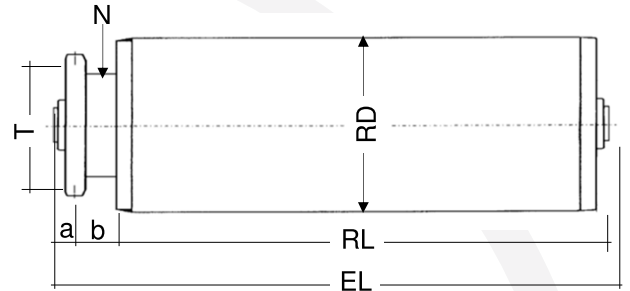

a=12mm, b=15,5mm, T=45,07mm, N=31,5mm

For information on accumulation drive, see Page 4.

**Stau = Friction / Fest = Fixed**

Pipe-Ø	Axle-Ø	Pipe design								Maximum load bearing capacity per roller*									
		S	SV	SG	SP	N	PG	PB	ALU	009	009N	011	013	017	021	021N	025	028	029
50x1,5	10,12,14	●	●	○	●	●			●	24	24	100	100	100	100	60	100		100
50x2	10,12,14	●	●	○	●	●							100	100	100	60	100	100	100
50x2,8	10,12,14						●	●		24	24	100			100	60	100		
50x3	10,12,14	●	●	○	●								100			100			
60x1,5	10,12,14	●	●	○	●					24	24	100	100	100	100	60	100		100
60x2	10,12,14	●	●	○	●								100	100	100	60	100	100	100
60,3x1,65	10,12,14					●				24	24	100			100	60	100		100
63x3	10,12,14						●	●		24	24	100			100	60	100		
63,5x2,9	10,12,14	●	●	○										100	60	100	100	100	100
80x2	10,12,14	●	●	○	●	●							100	100	100	60	100		100

Counter-bearing	Friction	Fixed	Pipe-Ø	Axle-Ø	EL=							
						IG	S	F	G	AG	BG	
009/009N	●	●		10,12	RL+	33						8
011	●	●		10,12	RL+	33						9
013	●	●		10,12	RL+	31						6
017	●	●		10,12,14	RL+	34						7
021/021N	●	●		10,12,14	RL+	31						10
025	●	●		10,12,14	RL+	31						10
028	●	●		10,12,14	RL+	37						7
029		●		10,12,14	RL+	34						7

\* - To determine the load bearing capacity of the axles and pipes, please use the chart on page 3.

Other designs upon request. Other designs upon request.

- - Design upon request
- - In the standard

Ordering example	AT1K 1/2z11,S,Fest 025-50x1,5 SV A12 IG8x15, EL=432
------------------	--

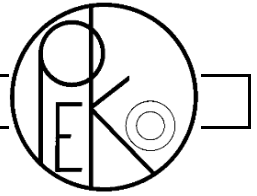

# Adjustable friction roller

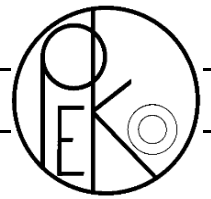

## AT1K 1/2z11,S,Stau "E"

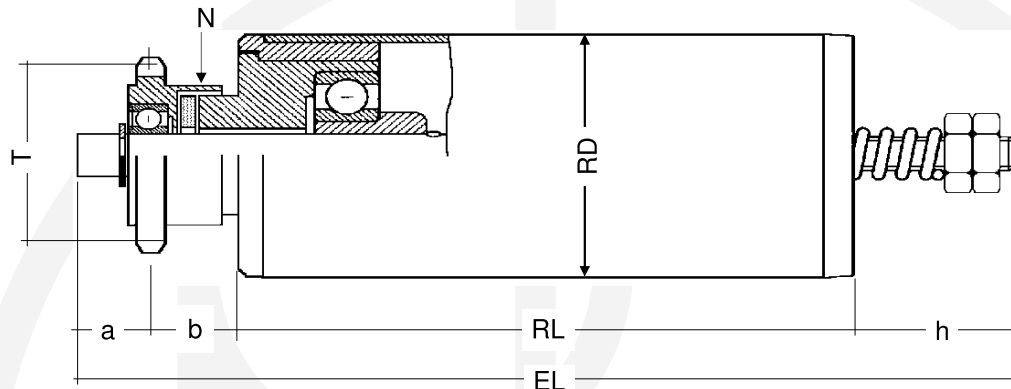

a = 12mm  
 b = 18mm  
 h = 29mm  
 N = 32mm  
 T = 45,07mm

Steel chain wheel 1/2"x5/16" z11 as accumulation drive with adjustable drive force. drive head with grooved ball bearing 6001 ZZ also available with 6001 2RS (AT1K 1/2z11,RS,Stau "E") and counterbearing 024E with 6002 ZZ also available with 6002 2RS (024RS). Axle has inside thread M8x15 on both sides.  
 By adjusting the nuts on the fine thread M12x1.25, the friction on the friction disc and thus the drive force is increased.

Maximum allowed conveying speed 0.5 m/sec.

**Stau = Friction**

Pipe-Ø	Axle-Ø	Pipe design								Maximum load bearing capacity per roller*											
		S	SV	SG	SP	N	PG	PB	ALU	024											
50x1,5	12	●	●	○	●	●			●	60											
50x2	12	●	●	○	●	●				60											
50x2,8	12						●	●		60											
60x1,5	12	●	●	○	●					60											
60x2	12	●	●	○	●					60											
60,3x1,65	12					●				60											
63x3	12						●	●		60											

Counter-bearing	Pipe-Ø	Axle-Ø	EL =	Internal thread IG	Spanner flat S	Spring axle F	Smooth G	External thread AG	Deposited external thread BG	
024E		12	RL +	59	●	●	●	●	●	10

--

Ordering example	AT1K 1/2z11,Stau "E" 024E-50x1,5 SV A12 IG8x15 EL=567
------------------	--

# Adjustable friction roller

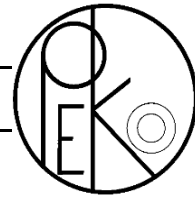

## AT1K 1/2z11,S,Stau "EK"

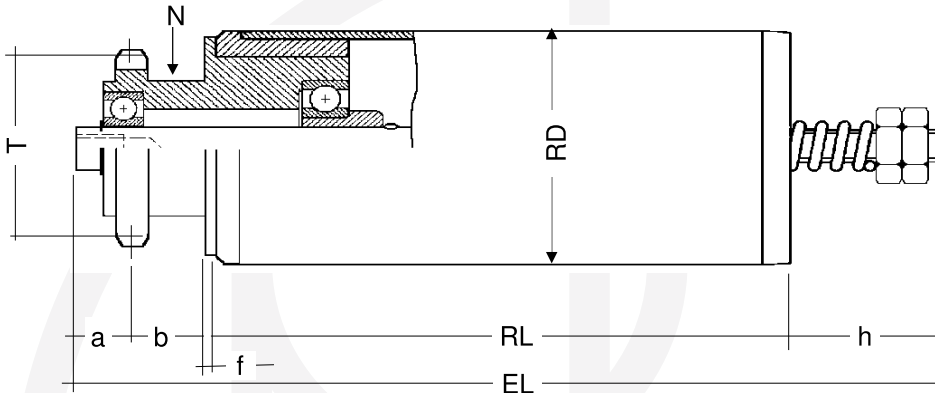

- a = 12mm
- b = 15,5mm
- f = 2mm
- h = 29mm
- N = 31,5mm
- T = 45,07mm

Steel chain wheel 1/2"x5/16" z11 as accumulation drive with adjustable drive force. Drive head with grooved ball bearing 6001 ZZ/6202 ZZ also available with 6001 2RS/ 6202 2RS (AT1K 1/2z11,RS,Stau "EK") and counterbearing 024E with 6002 ZZ also available with 6002 2RS (024RS). Axle with inside thread M8x15 on both sides. By adjusting the nuts on the fine thread, M12x1.25 the friction of the chain wheel as well as the anti-friction bushing and thus the drive force is increased.

Maximum allowed conveying speed 0.5 m/sec.

**Stau = Friction**

Pipe-Ø	Axle-Ø	Pipe design								Maximum load bearing capacity per roller*												
		S	SV	SG	SP	N	PG	PB	ALU	024												
50x1,5	12	●	●	○	●	●			●	60												
50x2	12	●	●	○	●	●				60												
50x2,8	12						●	●		60												
60x1,5	12	●	●	○	●					60												
60x2	12	●	●	○	●					60												
60,3x1,65	12					●				60												
63x3	12						●	●		60												

Counter-bearing	Pipe-Ø	Axle-Ø	EL =	Internal thread IG	Spanner flat S	Spring axle F	Smooth G	External thread AG	Deposed external thread BG	
024E		12	RL +	59						10

\* - To determine the load bearing capacity of the axles and pipes, please use the chart on page 3.

Other designs upon request.

- - Design upon request
- - In the standard

Ordering example	AT1K 1/2z11,Stau "EK" 024E-50x1,5 SV A12 IG8x15 EL=567
------------------	---

# Powered conveyor roller with single chain wheel

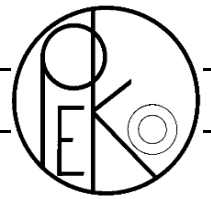

## AT1K 1/2z11, verschweisst

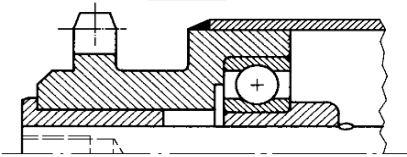

Steel chain wheel 1/2"x5/16" z11 with rack and pinion gearing welded with pipe.

Grooved ball bearing 6202 also available as ZZ or 2RS.

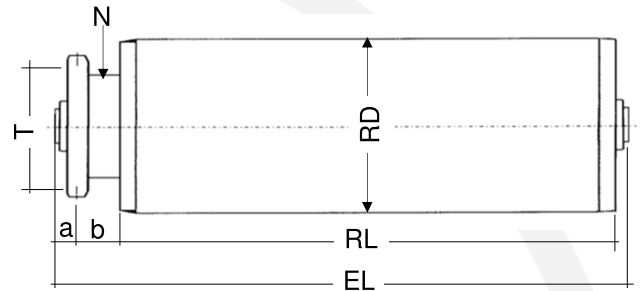

a=12mm, b=15,5mm, T=45,07mm, N=31,5mm

**verschweisst = welded**

Pipe-Ø	Axle-Ø	Pipe design								Maximum load bearing capacity per roller*						
		S	SV	SG	SP	N	PG	PB	ALU	013	017	021	021N	025	028	029
50x1,5	10,12,14	●	●	○	●	●				100	100	100	60	100		100
50x2	10,12,14	●	●	○	●					100	100	100	60	100	100	100
50x3	10,12,14	●	●	○	●						100			100		
60x1,5	10,12,14	●	●	○	●					100	100	100	60	100		100
60x2	10,12,14	●	●	○	●					100	100	100	60	100	100	100
63,5x2,9	10,12,14	●	●	○								100	60	100	100	
80x2	10,12,14	●	●	○	●	●				100	100	100	60	100		100

Counter-bearing	Pipe-Ø	Axle-Ø	EL=								
				IG	S	F	G	AG	BG		
013		10,12	RL+	31							6
017		10,12,14	RL+	34							7
021/021N		10,12,14	RL+	31							10
025		10,12,14	RL+	31							10
028		10,12,14	RL+	37							7
029		10,12,14	RL+	33							7

\* - To determine the load bearing capacity of the axles and pipes, please use the chart on page 3.

Other designs upon request.

- - Design upon request
- - In the standard

Ordering example	AT1K 1/2z11, verschweisst 025-50x1,5 SV A12 IG8x15, EL=432
------------------	---

# Powered conveyor roller with single chain wheel

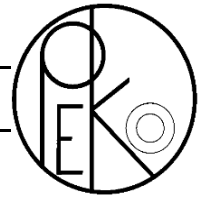

## AT1K 1/2z14,K,Stau / AT1K 1/2z14,K,Fest

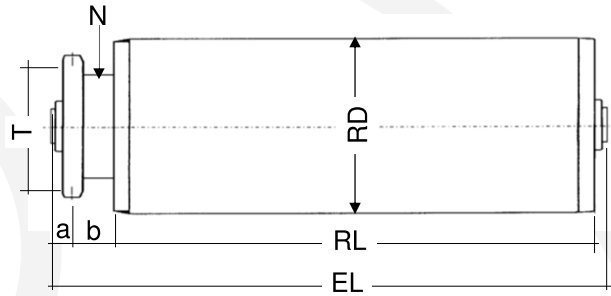
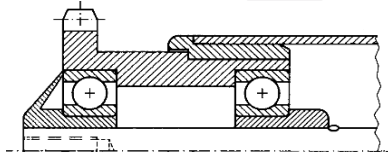

Chain wheel 1/2"x5/16" z14 of thermoplastic material as an accumulation drive (Friction) or as fixed drive (Fixed) with press fit. Grooved ball bearing 6202 also available as ZZ or 2RS.

Not suitable for stop and go as fixed drive.

For information on accumulation drive, see Page 4.

a=11,5mm, b=18mm, T=57,07mm, N=43mm

**Stau = Friction**

**Fest = Fixed**

Pipe-Ø	Axle-Ø	Pipe design								Maximum load bearing capacity per roller*										
		S	SV	SG	SP	N	PG	PB	ALU	009	009N	011	013	017	021	021N	025	028	029	
50x1,5	10,12,14	●	●	○	●	●			●	24	24	40	40	40	40	40	40	40	40	40
50x2	10,12,14	●	●	○	●	●				24	24	40	40	40	40	40	40	40	40	40
50x2,8	10,12,14						●	●		24	24	40			40	40	40			
50x3	10,12,14	●	●	○	●									40			40			
60x1,5	10,12,14	●	●	○	●					24	24	40	40	40	40	40	40			40
60x2	10,12,14	●	●	○	●								40	40	40	40	40	40	40	40
60,3x1,65	10,12,14					●				24	24	40			40	40	40			40
63x3	10,12,14						●	●		24	24	40			40	40	40			
63,5x2,9	10,12,14	●	●	○											40	40	40	40		
80x2	10,12,14	●	●	○	●	●							40	40	40	40	40			40

Counter-bearing	Friction		Fixed		Pipe-Ø	Axle-Ø	EL=	IG	S	F	G	AG	BG	
	Friction	Fixed	Friction	Fixed										
009/009N	●	●				10,12	RL+	35						8
011	●	●				10,12	RL+	35						9
013	●	●				10,12	RL+	34						6
017	●	●				10,12,14	RL+	36						7
021/021N	●	●				10,12,14	RL+	35						10
025	●	●				10,12,14	RL+	35						10
028	●	●				10,12,14	RL+	39						7
029		●				10,12,14	RL+	37						7

\* - To determine the load bearing capacity of the axles and pipes, please use the chart on page 3.

Other designs upon request.

- - Design upon request
- - In the standard

Ordering example

AT1K 1/2z14,K,Stau  
025-50x1,5 SV A12 IG8x15, EL=432

# Powered conveyor roller with single chain wheel

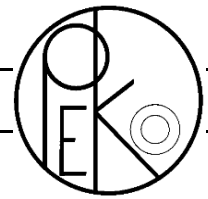

## AT1K 1/2z14,S,Stau / AT1K 1/2z14,S,Fest

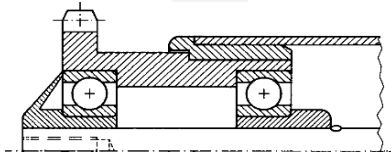

Steel chain wheel 1/2"x5/16" z14 with rack and pinion gearing as accumulation drive (Friction) or as fixed drive (Fixed) with press fit grooved ball bearing 6202 also available as ZZ or 2RS.  
Not suitable for stop and go as fixed drive.

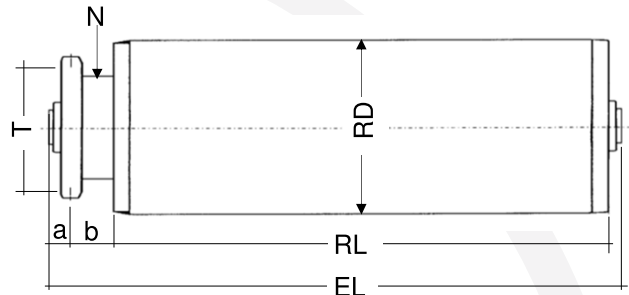

a=11,5mm, b=18mm, T=57,07mm, N=43mm

For information on accumulation drive, see Page 4.

**Stau = Friction / Fest = Fixed**

Pipe-Ø	Axle-Ø	Pipe design								Maximum load bearing capacity per roller*										
		S	SV	SG	SP	N	PG	PB	ALU	009	009N	011	013	017	021	021N	025	028	029	
50x1,5	10,12,14	●	●	○	●	●			●	24	24	100	100	100	100	60	100		100	
50x2	10,12,14	●	●	○	●	●						100	100	100	60	100	100	100		
50x2,8	10,12,14						●	●		24	24	100			100	60	100			
50x3	10,12,14	●	●	○	●									100		100				
60x1,5	10,12,14	●	●	○	●					24	24	100	100	100	100	60	100		100	
60x2	10,12,14	●	●	○	●	●							100	100	100	60	100	100	100	
60,3x1,65	10,12,14					●				24	24	100			100	60	100		100	
63x3	10,12,14						●	●		24	24	100			100	60	100			
63,5x2,9	10,12,14	●	●	○											100	60	100	100		
80x2	10,12,14	●	●	○	●	●							100	100	100	60	100		100	

Counter-bearing			Pipe-Ø	Axle-Ø	EL=	Internal thread IG	Spanner flat S	Spring axle F	Smooth G	External thread AG	Deposited external thread BG	
	Friction	Fixed										
009/009N	●	●		10,12	RL+	35						8
011	●	●		10,12	RL+	35						9
013	●	●		10,12	RL+	34						6
017	●	●		10,12,14	RL+	36						7
021/021N	●	●		10,12,14	RL+	34						10
025	●	●		10,12,14	RL+	34						10
028	●	●		10,12,14	RL+	39						7
029		●		10,12,14	RL+	36						7

\* - To determine the load bearing capacity of the axles and pipes, please use the chart on page 3.

Other designs upon request.

○ - Design upon request  
● - In the standard

Ordering example

AT1K 1/2z14,S,Stau  
025-50x1,5 SV A12 IG8x15, EL=432

# Adjustable friction roller

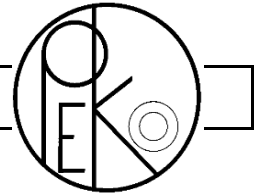

## AT1K 1/2z14,S,Stau "EK"

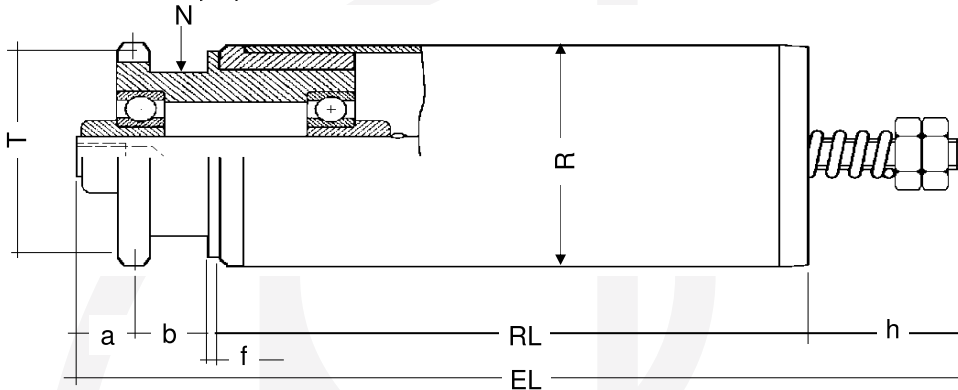

- a = 11,5mm
- b = 18mm
- f = 2mm
- h = 29mm
- N = 43mm
- T = 57,07mm

Steel chain wheel 1/2"x5/16" z14 as accumulation drive with adjustable drive force. Drive head with grooved ball bearing 6202 ZZ also available with 6202 2RS (AT1K 1/2z14,RS,Stau "EK") and counterbearing 024E with 6002 ZZ also available with 6002 2RS (024RS). Axle with inside thread M8x15 on both sides. By adjusting the nuts on the fine thread M12x1.25, the friction of the chain wheel as well as the anti-friction bushing and thus the drive force is increased.

Maximum allowed conveying speed 0.5 m/sec.

**Stau = Friction**

Pipe-Ø	Axle-Ø	Pipe design								Maximum load bearing capacity per roller*											
		S	SV	SG	SP	N	PG	PB	ALU	024											
50x1,5	12	●	●	○	●	●			●	60											
50x2	12	●	●	○	●	●				60											
50x2,8	12						●	●		60											
60x1,5	12	●	●	○	●					60											
60x2	12	●	●	○	●					60											
60,3x1,65	12					●				60											
63x3	12						●	●		60											

Counter-bearing	Pipe-Ø	Axle-Ø	EL =	Internal thread IG	Spanner flat S	Spring axle F	Smooth G	External thread AG	Deposited external thread BG	
024E		12	RL +	61						10

\* - To determine the load bearing capacity of the axles and pipes, please use the chart on page 3.

Other designs upon request.

- - Design upon request
- - In the standard

Ordering example

AT1K 1/2z14,Stau "EK"  
024E-50x1,5 SV A12 IG8x15, EL=567

# Powered conveyor roller with single chain wheel

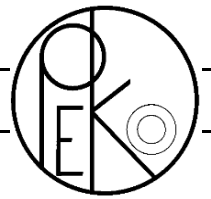

## AT1K 1/2z14,verschweisst

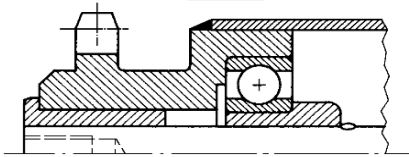

Steel chain wheel 1/2"x5/16" z14 with rack and pinion gearing welded with pipe. Grooved ball bearing 6202/6003 also available as ZZ or 2RS.

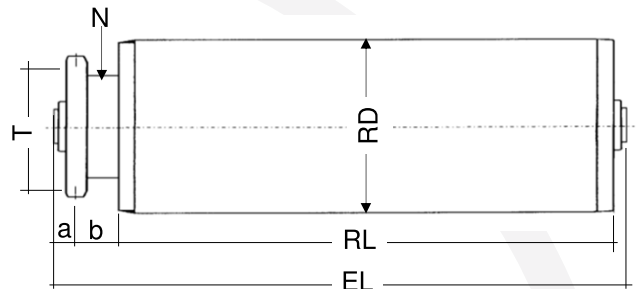

a=11,5mm, b=18mm, T=57,07mm, N=43mm

**verschweisst = welded**

Pipe-Ø	Axle-Ø	Pipe design								Maximum load bearing capacity per roller*						
		S	SV	SG	SP	N	PG	PB	ALU	013	017	021	021N	025	028	029
50x1,5	10,12,14,15,17	●	●	○	●					150	150	150	60	150		150
50x2	10,12,14,15,17	●	●	○	●					150	150	150	60	150	150	150
50x3	10,12,14,15,17	●	●	○	●						150			150		
60x1,5	10,12,14,15,17	●	●	○	●					150	150	150	60	150		150
60x2	10,12,14,15,17	●	●	○	●					150	150	150	60	150	150	150
63,5x2,9	10,12,14,15,17	●	●	○								150	60	150	150	
80x2	10,12,14,15,17	●	●	○	●					150	150	150	60	150		150

Counter-bearing	Pipe-Ø	Axle-Ø	EL=	Axle design							
				IG	S	F	G	AG	BG		
013		10,12	RL+	35							6
017		10,12,14	RL+	37							7
021/021N		10,12,14	RL+	33							10
025		10,12,14,15,17	RL+	33							10
028		10,12,14,15,17	RL+	40							7
029		10,12,14,15,17	RL+	35							7

\* - To determine the load bearing capacity of the axles and pipes, please use the chart on page 3.

Other designs upon request.

- - Design upon request
- - In the standard

Ordering example

AT1K 1/2z14,verschweisst  
025-50x1,5 SV A12 IG8x15, EL=432

# Powered conveyor roller with single chain wheel

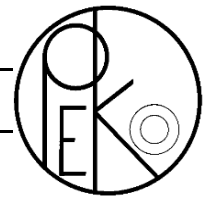

## AT1K 5/8z12,S,Stau / AT1K 5/8z12,S,Fest

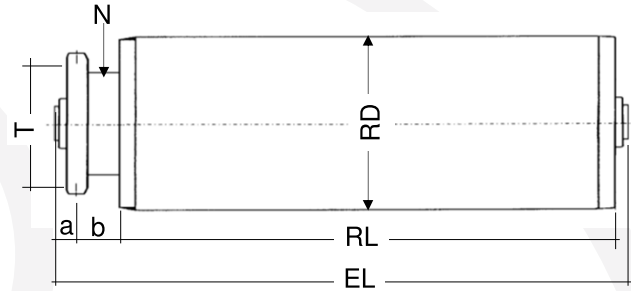
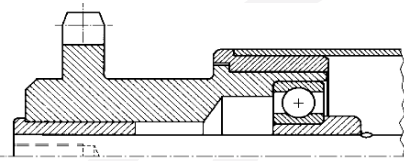

Steel chain wheel 5/8"x3/8" z12 with rack and pinion gearing as accumulation drive (Friction) or as fixed drive (Fixed) with press fit grooved ball bearing 6202/6003 also available as ZZ or 2RS. Not suited for stop and go operation as fixed drive.

For information on accumulation drive, see page 4.

a = 15mm, b = 28mm, T = 61,34mm, N = 36mm

**Stau = Friction / Fest = Fixed**

Pipe-Ø	Axle-Ø	Pipe design								Maximum load bearing capacity per roller*			
		S	SV	SG	SP	N	PG	PB	ALU	017	025	028	029
50x1,5	12,14,17	●	●	○	●	●			●	100	100		
50x2	12,14,17	●	●	○	●	●				100	100	100	100
50x3	12,14,17	●	●	○	●					100	100		100
60x1,5	12,14,17	●	●	○	●					100	100		100
60x2	12,14,17	●	●	○	●	●				100	100	100	100
60,3x1,65	12,14,17					●					100		100
63,5x2,9	12,14,17	●	●	○							100	100	100
80x2	12,14,17	●	●	○	●	●				100	100		100

Counter-bearing	Friction		Fixed		Pipe-Ø	Axle-Ø	EL=							
	IG	S	F	G				AG	BG					
017	●	●			12,14	RL+	49							7
025	●	●			12,14,17	RL+	47							10
028	●	●			12,14,17	RL+	52							7
029					12,14,17	RL+	49							7

\* - To determine the load bearing capacity of the axles and pipes, please use the chart on page 3.

Other designs upon request.

○ - Design upon request  
● - In the standard

Ordering example

AT1K 5/8z12,verschweisst  
029-63,5x2,9 SV A14 IG8x15, EL=432



# Powered conveyor roller with single chain wheel

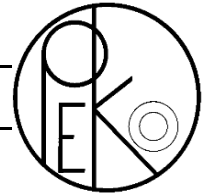

AT1K 5/8z12,S,Stau / AT1K 5/8z13,S,Stau / AT1K 5/8z15,S,Stau

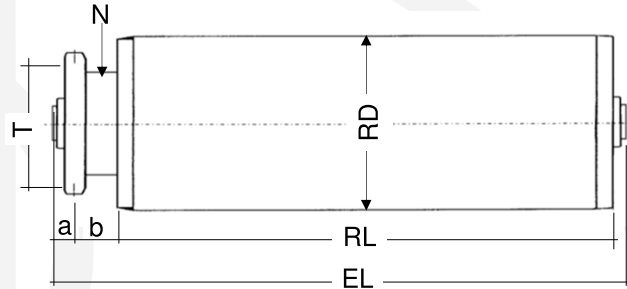
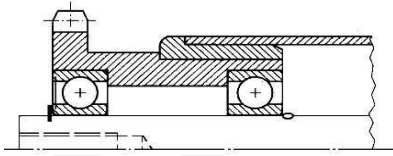

Steel chain wheel 5/8"x3/8" z12 with rack and pinion gearing as accumulation drive (Friction). Grooved ball bearing 6204/6004 also available as ZZ or 2RS.

For information on accumulation drive, see page 4.

z12: a = 18mm, b = 18mm, T = 61.34mm, N = 36mm  
 z13: a = 18mm, b = 18mm, T = 66.32mm, N = 51mm  
 z15: a = 18mm, b = 18mm, T = 76.36mm, N = 60mm

**Stau = Friction**

Pipe-Ø	Axle-Ø	Pipe design								Maximum load bearing capacity per roller*																	
		S	SV	SG	SP	N	PG	PB	ALU	034	037	044															
80x2	17/20	●	●	○	●	●				200	200	200															
88,9x2,9	17/20	●	●	○	●	●				200	200	200															

Counter-bearing	Pipe-Ø	Axle-Ø			EL=	Internal thread IG	Spanner flat S	Spring axle F	Smooth G	External thread AG	Deposited external thread BG		
		z12	z13	z15									
034		17	20	17/20	RL+	43							8
037		17	20	17/20	RL+	43							10
044		17	20	17/20	RL+	43							8

\* - To determine the load bearing capacity of the axles and pipes, please use the chart on page 3.

Other designs upon request.

- - Design upon request
- - In the standard

Ordering example

AT1K 5/8z13,S,Stau  
 034-88,9x2,9 SV A20 IG12x18, EL=432

# Powered conveyor roller with single chain wheel

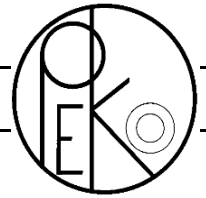

## AT1K 5/8z13,verschweisst / AT1K 5/8z15,verschweisst

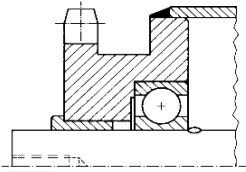

Steel chain wheel 5/8"x3/8" z13 or z15 with rack and pinion gearing welded with pipe.  
Grooved ball bearing 6204 also available as ZZ or 2RS.

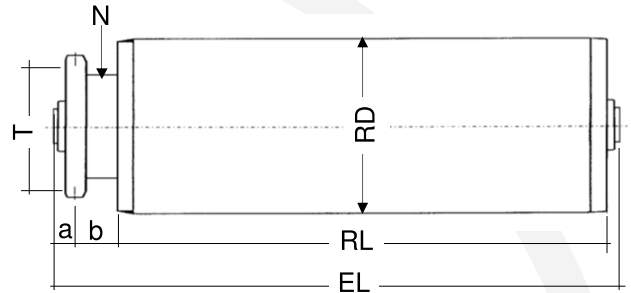

with z13: a = 18mm, b = 18mm, T = 66,32mm, N = 51mm  
with z15: a = 18mm, b = 18mm, T = 76,36mm, N = 60mm

**verschweisst = welded**

Pipe-Ø	z13 / z15 / z15		Pipe design								Maximum load bearing capacity per roller*										
	Axle-Ø		S	SV	SG	SP	N	PG	PB	ALU	033	045									
63,5x2,9	20		●	●	○						480										
80x2	20		●	●	○	●					480										
80x3	20		●	●	○	●					480										
88,9x2,9	20	25	●	●	○	●					480	480									
108x3,6	20	25	●	●	○	●					480	480									
133x4	20	25	●	●	○	●						480									

Counter-bearing	Pipe-Ø	Axle-Ø	EL=							
				IG	S	F	G	AG	BG	
033		20,25	RL+	41						8
045		20,25	RL+	41						10

\* - To determine the load bearing capacity of the axles and pipes, please use the chart on page 3.

Other designs upon request.

- - Design upon request
- - In the standard

Ordering example

AT1K 5/8z15,verschweisst  
033-88,9x2,9 SV A20 IG10x15, EL=967

# Powered conveyor roller with single chain wheel

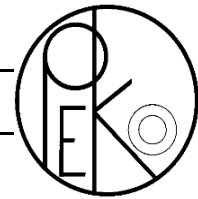

## AT1K 3/4z13,verschweisst

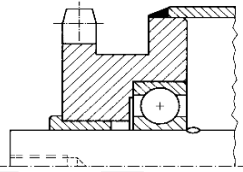

Steel chain wheel 3/4"x7/16" z13 with rack and pinion gearing with pipe welded. Grooved ball bearing 6204/6005 also available as ZZ or 2RS.

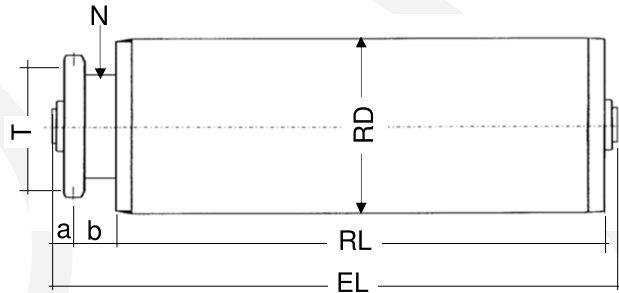

a = 18mm, b = 18mm, T = 79,59mm, N = 60mm

**verschweisst = welded**

Pipe-Ø	Axle-Ø	Pipe design								Maximum load bearing capacity per roller*														
		S	SV	SG	SP	N	PG	PB	ALU	033	045													
80x2	20,25	●	●	○	●							480												
80x3	20,25	●	●	○	●							480												
88,9x2,9	20,25	●	●	○	●							480												
108x3,6	20,25	●	●	○	●							480												
133x4	20,25	●	●	○	●								480											

Counter-bearing	Pipe-Ø	Axle-Ø	EL=	Internal thread IG	Spanner flat S	Spring axle F	Smooth G	External thread AG	Deposited external thread BG	Maximum load bearing capacity per roller*	
										033	045
033		20,25	RL+	41							8
045		20,25	RL+	41							10

\* - To determine the load bearing capacity of the axles and pipes, please use the chart on page 3.

Other designs upon request.

- - Design upon request
- - In the standard

Ordering example

AT1K 3/4z13,verschweisst  
033-88,9x2,9 SV A20 IG10x15, EL=967

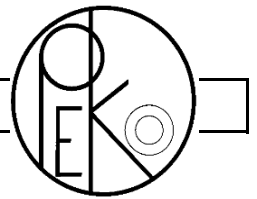

### Centre distances for chains

Chain links	3/8" x 7/32" z=12	1/2" x 5/16" z=14	5/8" x 3/8" z=15	3/4" x 7/16 z=13	
22	47,6				
24	57,2				
26	66,7	76,2		123,8	
28	76,2	88,9	103,2	142,9	
30	85,8	101,6	119,1	161,9	
32	95,3	114,3	134,9	181,0	
34	104,8	127,0	150,8	200,0	
36	114,3	139,7	166,7	219,1	
38	123,9	152,4	182,6	238,1	
40	133,4	165,1	198,5	257,2	
42	142,9	177,8	214,3	276,2	
44	152,4	190,5	230,2	295,3	
46		203,2	246,1	314,3	
48		215,9	261,9	333,4	
50		228,6	277,8	352,4	
52		241,3	293,7	371,5	
54		254,0	309,6	390,5	
56		266,7	325,4	409,6	
58		279,4	341,3	428,6	
60		292,1	357,2	447,7	

### Centre distance für ribbed belt

Number of ribbings	Designation				Conveyor weight
	PJ 256	PJ 286	PJ 336	PJ 376	
2	60	75	100	120	1-40kg
3	60	75	100	120	41-200kg

Other designs upon request

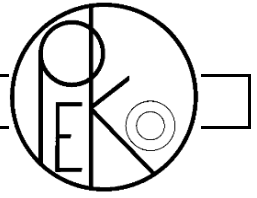

# Powered conveyor roller with double chain wheel

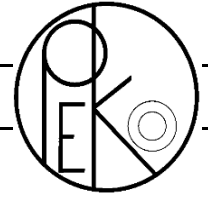

## AT2K 3/8z12,S,Stau / AT2K 3/8z12,S,Fest

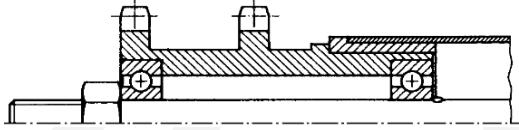

Steel chain wheel 3/8"x7/32" z12 with Plain toothing als accumulation drive (Friction) or as fixed drive (Fixed) with press fit. Grooved ball bearing 608 ZZ also available as 2RS. Not suitable for stop and go as fixed drive.

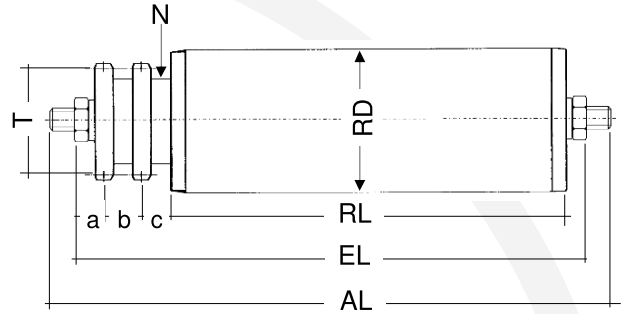

For information on accumulation drive, see Page 4.

a = 9,5mm, b = 20mm, c = 12,5mm, T = 36,8mm  
N = 27mm

**Stau = Friction / Fest = Fixed**

Pipe-Ø	Axle-Ø	Pipe design							Maximum load bearing capacity per roller*										
		S	SV	SG	SP	N	PG	PB	ALU	001	001N	005							
30x1	8	●	●	○	●	●				14	14	40							
30x1,8	8						●	●		14	14	40							
32x2	8	●	●	○	●	●				14	14	40							

Counter-bearing			Pipe-Ø	Axle-Ø	EL=	Internal thread IG	Spanner flat S	Spring axle F	Smooth G	External thread AG	Deposited external thread BG	
	Friction	Fixed										
001/001N	●	●		8	RL+							11
005	●	●		8	RL+							6

\* - To determine the load bearing capacity of the axles and pipes, please use the chart on page 3.

Other designs upon request.

- - Design upon request
- - In the standard

Ordering example

AT2K 3/8z12,S,Fest  
005-30x1 SV A8 AG8x15, EL=432

# Powered conveyor roller with double chain wheel

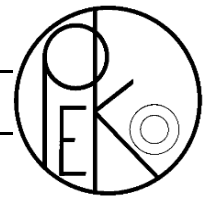

## AT2K 1/2z14,K,Stau / AT2K 1/2z14,K,Fest

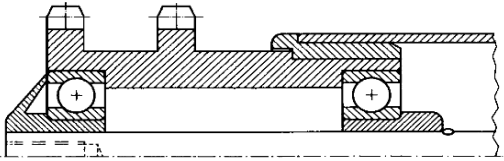

Chain wheel 1/2"x5/16" z14 of thermoplastic material as accumulation drive (Friction) or as fixed drive (Fixed) with press fit. Grooved ball bearing 6202 also available as ZZ or 2RS. Not suitable for stop and go as fixed drive.

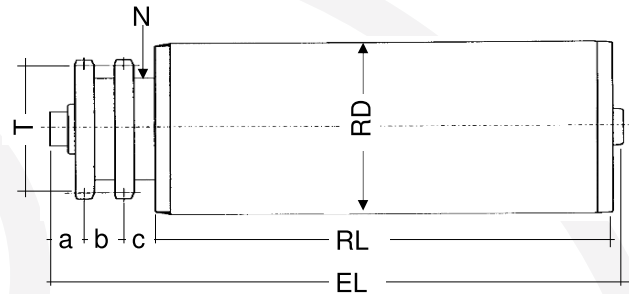

a = 11,5mm, b = 21mm, c = 18mm, T = 57,07mm  
N = 42mm

For information on accumulation drive, see Page 4.

**Stau = Friction / Fest = Fixed**

Pipe-Ø	Axle-Ø	Pipe design								Maximum load bearing capacity per roller*										
		S	SV	SG	SP	N	PG	PB	ALU	009	009N	011	013	017	021	021N	025	028	029	
50x1,5	10,12,14	●	●	○	●	●			●	24	24	40	40	40	40	40	40		40	
50x2	10,12,14	●	●	○	●	●							40	40	40	40	40	40	40	
50x2,8	10,12,14						●	●		24	24	40			40	40	40			
50x3	10,12,14	●	●	○	●									40			40			
60x1,5	10,12,14	●	●	○	●					24	24	40	40	40	40	40	40			40
60x2	10,12,14	●	●	○	●								40	40	40	40	40	40	40	
60,3x1,65	10,12,14					●				24	24	40			40	40	40			40
63x3	10,12,14						●	●		24	24	40			40	40	40			
63,5x2,9	10,12,14	●	●	○											40	40	40	40		
80x2	10,12,14	●	●	○	●	●							40	40	40	40	40			40

Counter-bearing	Friction		Fixed		Pipe-Ø	Axle-Ø	EL=	Internal thread IG	Spanner flat S	Spring axle F	Smooth G	External thread AG	Deposited external thread BG	
	Friction	Fixed	Friction	Fixed										
009/009N	●	●	●	●		10,12	RL+	56						8
011	●	●	●	●		10,12	RL+	56						9
013	●	●	●	●		10,12	RL+	55						6
017	●	●	●	●		10,12,14	RL+	57						7
021/021N	●	●	●	●		10,12,14	RL+	57						10
025	●	●	●	●		10,12,14	RL+	57						10
028	●	●	●	●		10,12,14	RL+	61						7
029						10,12,14	RL+	58						7

\* - To determine the load bearing capacity of the axles and pipes, please use the chart on page 3.\*

Other designs upon request.

- - Design upon request
- - In the standard

Ordering example

AT2K 1/2z14,K,Stau  
025-50x1,5 SV A12 IG8x15, EL=432

# Powered conveyor roller with double chain wheel

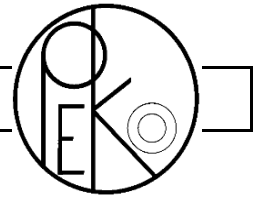

## AT2K 1/2z14,S,Stau / AT2K 1/2z14,S,Fest

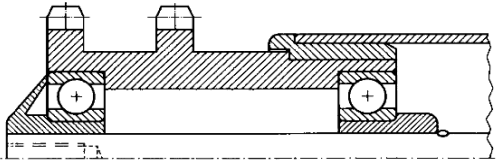

Steel chain wheel 1/2"x5/16" z14 as accumulation drive (Friction) or as fixed drive (Fixed) with press fit. Grooved ball bearing 6202 also available as ZZ or 2RS. Not suitable for stop and go as fixed drive.

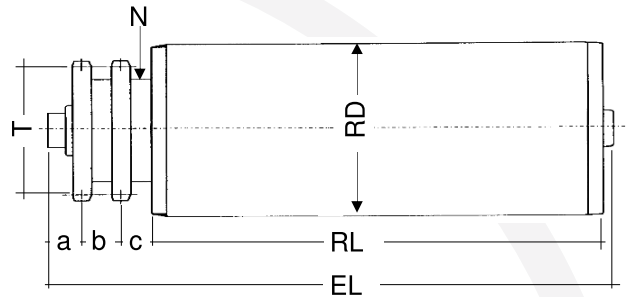

For information on accumulation drive, see Page 4.

a = 11,5mm, b = 21mm, c = 18mm, T = 57,07mm  
N=43mm

**Stau = Friction / Fest = Fixed**

Pipe-Ø	Axle-Ø	Pipe design								Maximum load bearing capacity per roller*											
		S	SV	SG	SP	N	PG	PB	ALU	009	009N	011	013	017	021	021N	025	028	029	037	
50x1,5	12,14	●	●	○	●	●			●	24	24	100	100	100	100	60	100		100		
50x2	12,14	●	●	○	●	●							100	100	100	60	100	100	100		
50x2,8	12,14						●	●		24	24	100			100	60	100				
50x3	12,14	●	●	○	●									100		100					
60x1,5	12,14	●	●	○	●					24	24	100	100	100	100	60	100		100		
60x2	12,14	●	●	○	●								100	100	100	60	100	100	100		
60,3x1,65	12,14					●				24	24	100			100	60	100		100		
63x3	12,14						●	●		24	24	100			100	60	100				
63,5x2,9	12,14,17	●	●	○											100	60	100	100		100	
80x2	12,14,17	●	●	○	●	●								100	100	100	60	100		100	100

Counter-bearing	Friction / Fixed		Pipe-Ø	Axle-Ø	EL=	IG						S	F	G	AG	BG	
	Friction	Fixed				IG	S	F	G	AG	BG						
009/009N	●	●		12	RL+	56											8
011	●	●		12	RL+	56											9
013	●	●		12	RL+	55											6
017	●	●		12,14	RL+	57											7
021/021N	●	●		12,14	RL+	55											10
025 / 026	●	●		12,14	RL+	54											10
028	●	●		12,14	RL+	60											7
029		●		12,14	RL+	57											7
037	●	●		17	RL+	57											10

\* - To determine the load bearing capacity of the axles and pipes, please use the chart on page 3.

Other designs upon request.

○ - Design upon request  
● - In the standard

Ordering example

AT2K 1/2z14,S,Stau  
025-50x1,5 SV A12 IG8x15, EL=432

# Adjustable friction roller

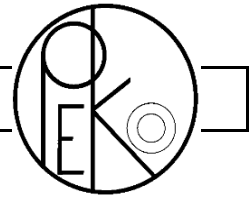

## AT2K 1/2z14,S,Stau "E"

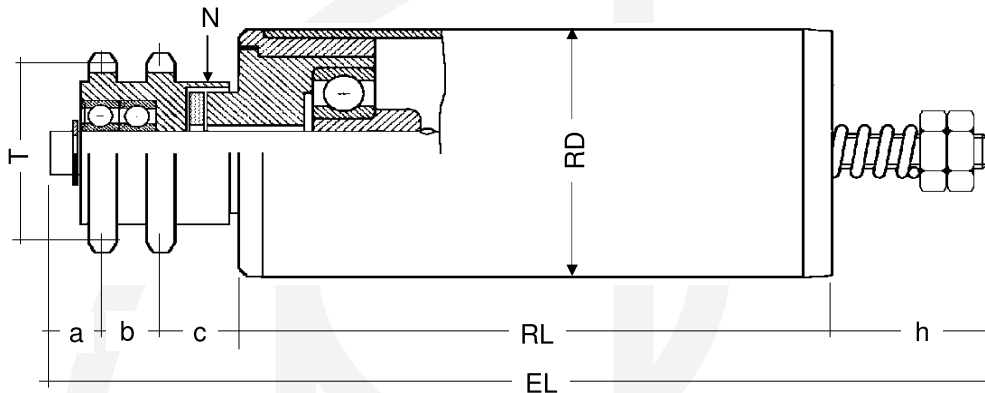

- a = 11.5mm
- b = 21mm
- c = 18mm
- h = 29mm
- N = 43mm
- T = 57,07mm

Steel chain wheel 1/2"x5/16" z14 as accumulation drive with adjustable drive force. Drive head with grooved ball bearing 6001 ZZ also available with 6001 2RS (AT1K 1/2z14,RS, Stau "E") and counterbearing 024E with 6202 ZZ also available with 6202 2RS (024RS). Axle with internal thread M8x15 on both sides.  
By adjusting the nuts on the fine thread M12x1.25, the friction on the friction disc and thus the drive force is increased.

Maximum allowed conveying speed 0.5 m/sec.

**Stau = Friction**

Pipe-Ø	Axle-Ø	Pipe design								Maximum load bearing capacity per roller*												
		S	SV	SG	SP	N	PG	PB	ALU	024												
50x1,5	12	●	●	○	●	●			●	60												
50x2	12	●	●	○	●	●				60												
50x2,8	12						●	●		60												
60x1,5	12	●	●	○	●					60												
60x2	12	●	●	○	●					60												
60,3x1,65	12					●				60												
63x3	12						●	●		60												

Counter-bearing	Pipe-Ø	Axle-Ø	EL=	Internal thread IG	Spanner flat S	Spring axle F	Smooth G	External thread AG	Deposited external thread BG
024E		12	RL +	80					10

\* - To determine the load bearing capacity of the axles and pipes, please use the chart on page 3.

Other designs upon request.

- - Design upon request
- - In the standard

Ordering example  
AT2K 1/2z14,Stau "E"  
024E-50x1,5 SV A12 IG8x15, EL=567

# Adjustable friction roller

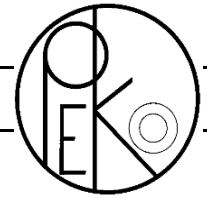

## AT2K 1/2z14,S,Stau "EK"

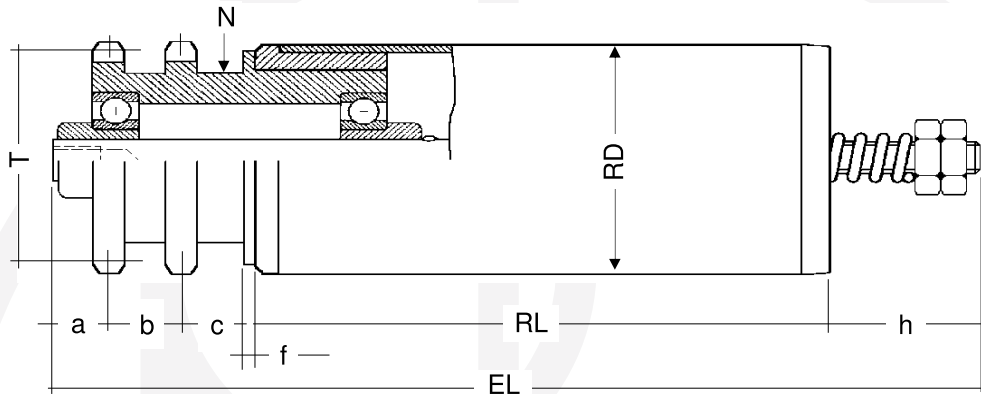

a =	11.5mm
b =	21mm
c =	18mm
f =	2mm
h =	29mm
N =	43mm
T =	57,07mm

Steel chain wheel 1/2"x5/16" z14 as accumulation drive with adjustable drive force. Drive head with grooved ball bearing 6202 ZZ also available with 6202 2RS (AT2K 1/2z14,RS, Stau"EK") and counterbearing 024E with 6202 ZZ also available with 6202 2RS (024RS). Axle with internal thread M8x15 on both sides. By adjusting the nuts on the fine thread M12x1.25, the friction of the chain wheel in the anti-friction bushing and thus the drive force is increased. Maximum allowed conveying speed 0.5 m/sec.

**Stau = Friction**

Pipe- Ø	Axle- Ø	Pipe design								Maximum load bearing capacity per roller*												
		S	SV	SG	SP	N	PG	PB	ALU	024												
50x1,5	12	●	●	○	●	●			●	60												
50x2	12	●	●	○	●	●				60												
50x2,8	12						●	●		60												
60x1,5	12	●	●	○	●					60												
60x2	12	●	●	○	●					60												
60,3x1,65	12					●				60												
63x3	12						●	●		60												

Counter-bearing	Pipe-Ø	Axle-Ø	EL =	Internal thread IG	Spanner flat S	Spring axle F	Smooth G	External thread AG	Deposed external thread BG	
024E		12	RL +	81						10

\* - To determine the load bearing capacity of the axles and pipes, please use the chart on page 3.

Other designs upon request.

- - Design upon request
- - In the standard

Ordering example	AT2K 1/2z14,Stau "EK" 024E-50x1,5 SV A12 IG8x15, EL=567
------------------	--

# Powered conveyor roller with double chain wheel

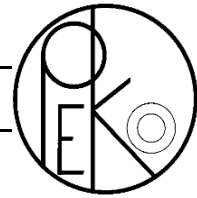

## AT2K 1/2z14,verschweisst

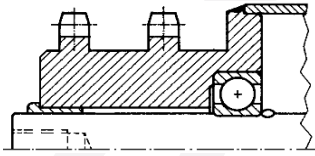

Steel chain wheel 1/2"x5/16" z14 welded with pipe. Grooved ball bearing 6202/6003 also available as ZZ or 2RS.

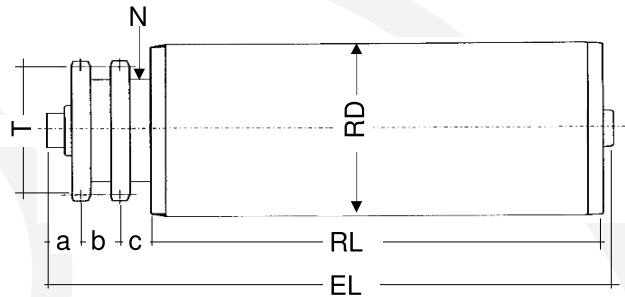

a = 11,5mm, b = 21mm, c = 18mm, T = 57,07mm  
N = 43mm

verschweisst = welded

Pipe-Ø	Axle-Ø	Pipe design							Maximum load bearing capacity per roller*									
		S	SV	SG	SP	N	PG	PB	ALU	013	017	021	021N	025	028	029	033	
50x1,5	12,14,15,17	●	●	○	●					150	150	150	60	150	150	150		
50x2	12,14,15,17	●	●	○	●					150	150	150	60	150	150	150		
50x3	12,14,15,17	●	●	○	●						150			150				
60x1,5	12,14,15,17	●	●	○	●					150	150	150	60	150		150		
60x2	12,14,15,17	●	●	○	●					150	150	150	60	150	150	150		
63,5x2,9	12,14,15,17,20	●	●	○	●							150	60	150	150		150	
80x2	12,14,15,17,20	●	●	○	●					150	150	150	60	150		150	150	
88.9x2.9	17,20	●	●	○	●												150	

Counter-bearing	Pipe-Ø	Axle-Ø	EL=								
				IG	S	F	G	AG	BG		
013		12	RL+	55							6
017		12,14	RL+	57							7
021/021N		12,14	RL+	55							10
025		12,14,15,17	RL+	55							10
028		12,14,15,17	RL+	60							7
029		12,14,15,17	RL+	55							7
033		17,20	RL+	55							7

\* - To determine the load bearing capacity of the axles and pipes, please use the chart on page 3.

Other designs upon request.

- - Design upon request
- - In the standard

Ordering example

AT2K 1/2z14,verschweisst  
025-50x1,5 SV A12 IG8x15, EL=550

# Powered conveyor roller with double chain wheel

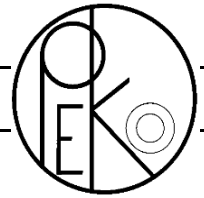

## AT2K 5/8z13,S,Stau / AT2K 5/8z15,S,Stau

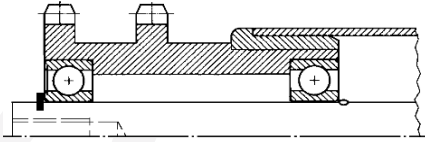

Steel chain wheel 5/8"x3/8" z13 or z15 as accumulation drive. Grooved ball bearing 6204/6004 ZZ also available as 2RS.

For information on accumulation drive, see Page 4.

**Stau = Friction**

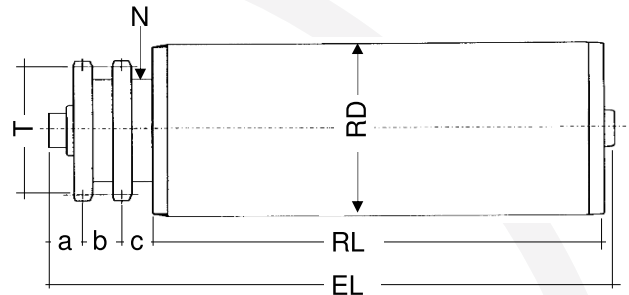

a = 18mm, b = 26mm, c = 18mm  
 bei z13: T = 66,32mm, N = 51mm  
 bei z15: T = 76,36mm, N = 60mm

Pipe-Ø	Axle-Ø	Pipe design							Maximum load bearing capacity per roller*								
		S	SV	SG	SP	N	PG	PB	ALU	034	037	044					
80x2	17/20	●	●	○	●	●				200	200	200					
88,9x2,9	17/20	●	●	○	●	●				200	200	200					

Counter-bearing	Pipe-Ø	Axle-Ø		EL=	Internal thread IG	Spanner flat S	Spring axle F	Smooth G	External thread AG	Deposited external thread BG	
		z13	z15								
034		20	17/20	RL+	69						8
037		20	17/20	RL+	69						10
044		20	17/20	RL+	69						8

\* - To determine the load bearing capacity of the axles and pipes, please use the chart on page 3.

Other designs upon request.

- - Design upon request
- - In the standard

Ordering example	AT2K 5/8z13,S,Stau 037-88,9x2,9 SV A20 IG12x18, EL=967
------------------	---

# Powered conveyor roller with double chain wheel

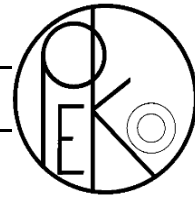

## AT2K 5/8z13,verschweisst / AT2K 5/8z15,verschweisst

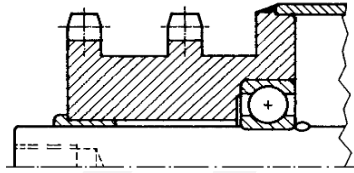

Steel chain wheel 5/8"x3/8" z13 or z15 welded with pipe. Grooved ball bearing 6204/6005 also available as ZZ or 2RS.

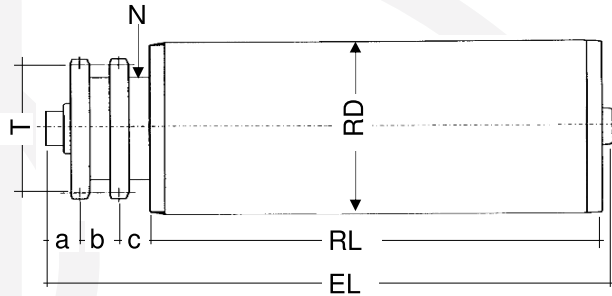

a = 18mm, b = 26mm, c = 18mm  
 with z13: T = 66,32mm, N = 51mm  
 with z15: T = 76,36mm, N = 58mm

**verschweisst = welded**

Pipe-Ø	Axle-Ø	Pipe design								Maximum load bearing capacity per roller*			
		S	SV	SG	SP	N	PG	PB	ALU	033	045	046	047
63,5x2,9	20	●	●	○						560	560	560	560
80x2	20,25	●	●	○	●					560	560	560	560
80x3	20,25	●	●	○	●					560	560	560	560
88,9x2,9	20,25	●	●	○	●					560	560	560	560
108x3,6	20,25	●	●	○						560	560	560	560
133x4	20,25	●	●	○						560	560	560	560

Counter-bearing	Pipe-Ø	Axle-Ø	EL=							
				IG	S	F	G	AG	BG	
033		20,25	RL+	67						8
045		20,25	RL+	67						10
046		20,25	RL+	67						10
047		20,25	RL+	67						10

\* - To determine the load bearing capacity of the axles and pipes, please use the chart on page 3.

Ordering example

AT2K 5/8z15,verschweisst  
 033-88,9x2,9 SV A20 IG10x15, EL=967

# Powered conveyor roller with double chain wheel

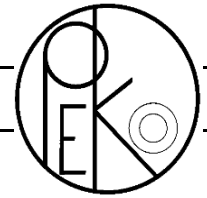

## AT2K 3/4z13,verschweisst

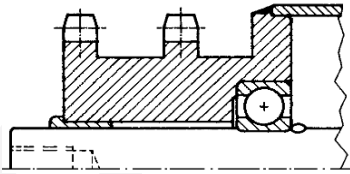

Steel chain wheel 3/4"x7/16" z13 welded with pipe.  
Grooved ball bearing 6204/6005 also available as ZZ or 2RS.

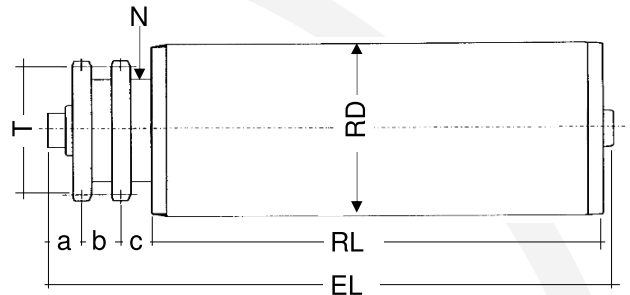

a = 18mm, b = 30mm, c = 18mm, T = 79,59mm  
N = 60mm

**verschweisst = welded**

Pipe-Ø	Axle-Ø	Pipe design								Maximum load bearing capacity per roller*			
		S	SV	SG	SP	N	PG	PB	ALU	033	045	046	047
80x2	20,25	●	●	○	●					560	560	560	560
80x3	20,25	●	●	○	●					560	560	560	560
88,9x2,9	20,25	●	●	○	●					560	560	560	560
108x3,6	20,25	●	●	○						560	560	560	560
133x4	20,25	●	●	○						560	560	560	

Counter-bearing	Pipe-Ø	Axle-Ø	EL=	Axle design						
				IG	S	F	G	AG	BG	
033		20,25	RL+	71						8
045		20,25	RL+	71						10
046		20,25	RL+	71						10
047		20,25	RL+	71						10

\* - To determine the load bearing capacity of the axles and pipes, please use the chart on page 3.

Other designs upon request.

- - Design upon request
- - In the standard

Ordering example	AT2K 3/4z13,verschweisst 033-88,9x2,9 SV A20 IG10x15, EL=967
------------------	---

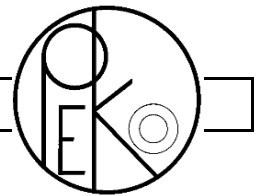

Various types of conical conveyor rollers are available:

1. Conical elements of thermoplastic material for internal radius of 500 or 800
2. PU or FBE-coated steel pipes according to any dimensions
3. Conical steel pipes uncoated, galvanised or stainless steel in any dimensions

Conical elements for internal radius of 500mm and pipe diameter of 30

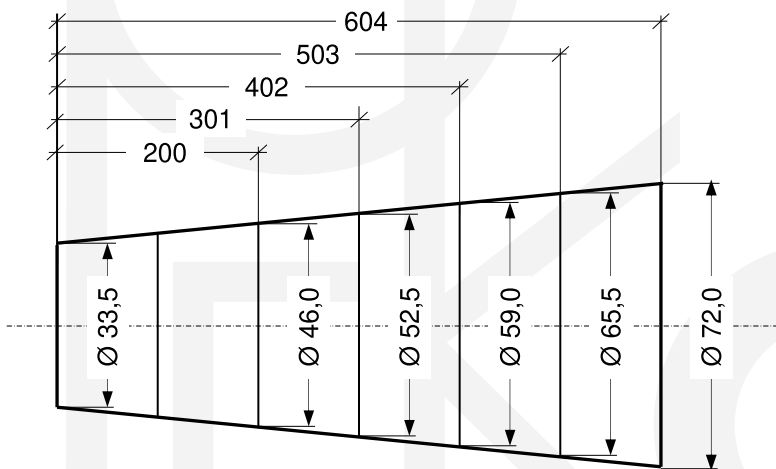

Conical elements for internal radius of 800mm and pipe diameter of 50

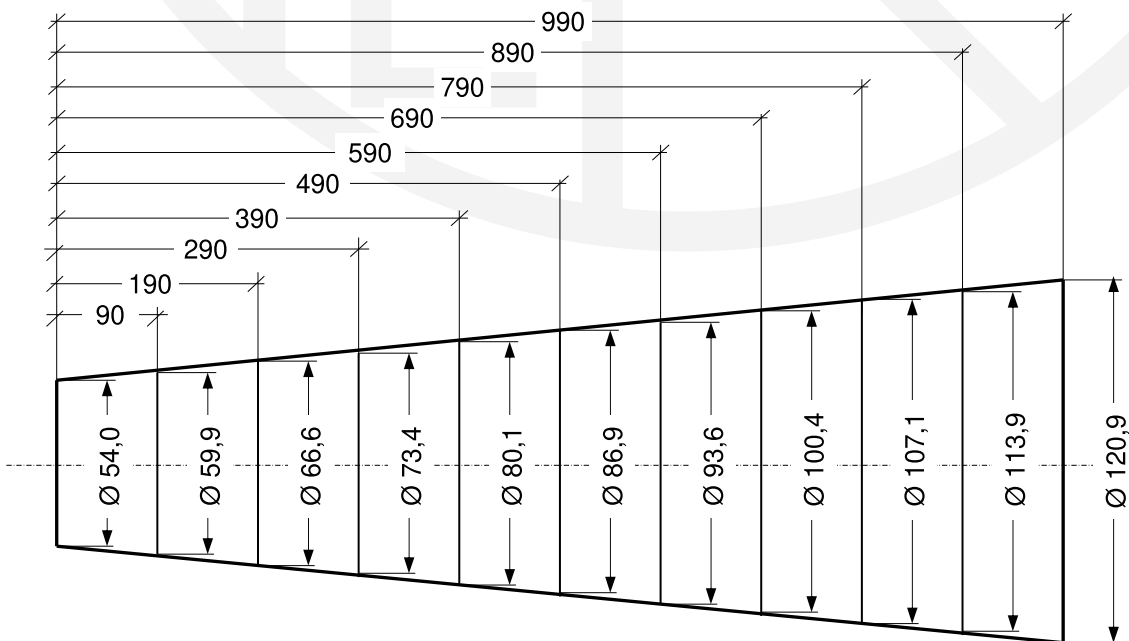

# Conical gravity conveyor roller

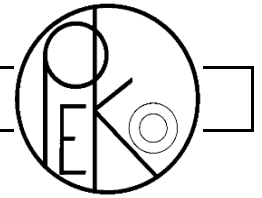

KST

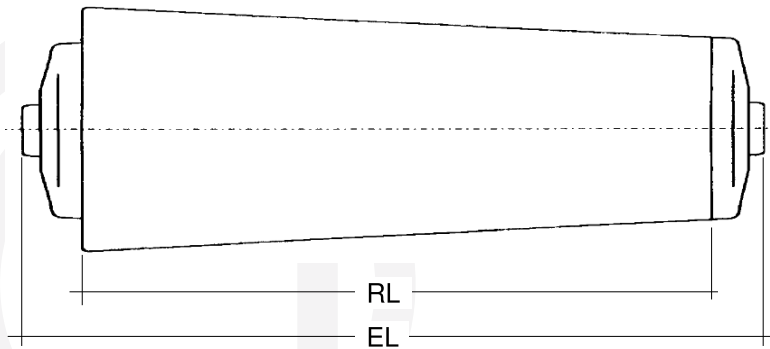

Gravity conveyor roller with inserted conical elements of thermoplastic material.  
Please find information on bearings with the corresponding gravity or powered conveyor roller.

Pipe-Ø	Axle-Ø	Pipe design								Maximum load bearing capacity per roller*											
		S	SV	SG	SP	N	PG	PB	ALU	001	001N	005	009	021	021N	025					
20x1.5	8	●	●			●				10	10										0
30x1	8,10	●	●			●				10	10	20									0
50x1,5	8,10,SK11,12,14	●	●			●														80	0
50x2,8	8,10,SK11,12,14						●	●						24	80	40	80				0

Counter-bearing	Pipe-Ø	Axle-Ø	EL =						
				IG	S	F	G	AG	BG
001/001N	20x1.5	8	RL +	22		22		35	
001/001N	30x1	8	RL +	23		23		36	
		10	RL +	23		23		33	
005	30x1	8	RL +					21	
		10	RL +	17					
021/021N		10	RL +	20	20	20	20	30	20
		SK11	RL +			20	20		
		12	RL +	20	20	20	20	32	20
025		14	RL +	20	20	20	20	34	20
		10	RL +	17	17	17	17	27	17
		SK11	RL +						
		12	RL +	17	17	17	17	29	17
		14	RL +	17	17	17	17	31	17

\* - To determine the load bearing capacity of the axles and pipes, please use the chart on page 3.

Other designs upon request.

- - Design upon request
- - In the standard

Ordering example	KST/025-50x1,5 SV A12 IG8x15 EL=507
------------------	-------------------------------------

# Conical conveyor roller with single chain wheel

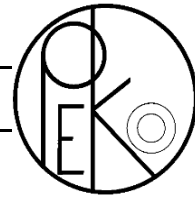

KT1K 1/2z11,K,Fest / KT1K 1/2z14,K,Fest  
 KT1K 1/2z11,S,Fest / KT1K 1/2z14,S,Fest

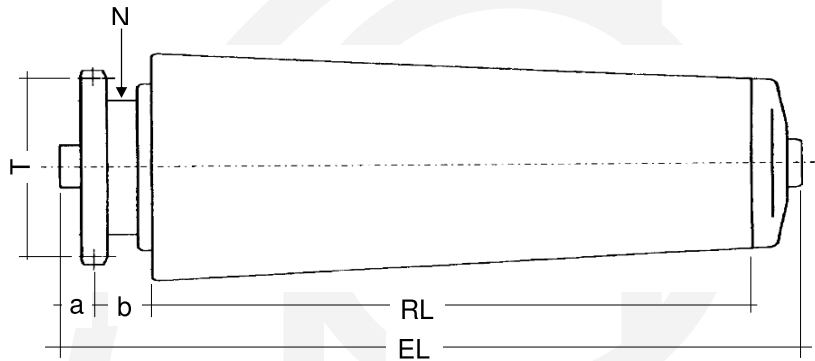

	KT1K 1/2z11	KT1K 1/2z14
a =	12mm	11,5mm
b =	20,5mm	23mm
N =	30mm	43mm
T =	45,07mm	57,07mm

Powered conveyor roller with single chain wheel of thermoplastic material (KT1K 1/2z11,K,Fest / KT1K 1/2z14,K,Fest ) or of steel (KT1K 1/2z11,S, Fest / KT1K 1/2z14,S,Fest) with inserted conical elements. Please find information on bearings with the corresponding gravity or powered conveyor roller.

**Fest = Fixed**

Pipe-Ø	Axle-Ø	Pipe design								Maximum load bearing capacity per roller*								
		S	SV	SG	SP	N	PG	PB	ALU	KT1K 1/2z11,K KT1K 1/2z14,K			KT1K 1/2z11,S KT1K 1/2z14,S					
										021	021N	025				021	021N	025
50x1,5	10,12,14	●	●			●						40				80		
50x2,8	10,12,14						●			40	40	40				80	40	80

Chain wheel	Counter-bearing	Axle-Ø	EL =	Internal thread						Deposited external thread
				IG	S	F	G	AG	BG	
KT1K 1/2z11	021/021N	10,12,14	RL +	42						0
	025	10,12,14	RL +	42						0
KT 1K1/2z14	021/021N	10,12,14	RL +	45						0
	025	10,12,14	RL +	45						0

\* - To determine the load bearing capacity of the axles and pipes, please use the chart on page 3.

Other designs upon request.

- - Design upon request
- - In the standard

Ordering example: KT1K 1/2z11,K,Fest  
 025-50x1,5 SV A12 IG8x15, EL=542

# Conical Conveyor roller with double chain wheel

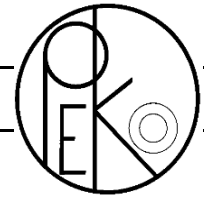

KT2K 3/8z12,S,Fest  
 KT2K 1/2z14,K,Fest / KT2K 1/2z14,S,Fest

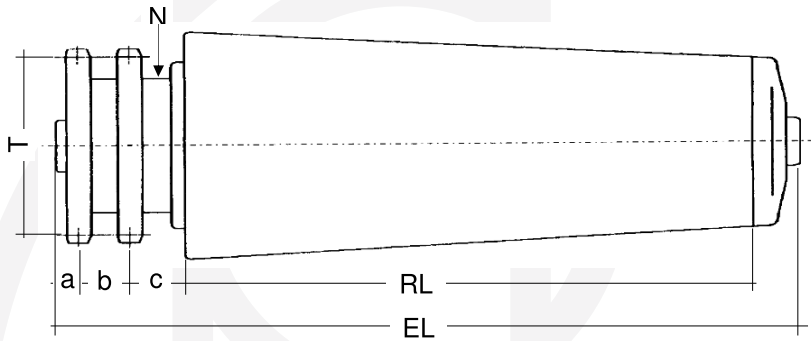

	KT2K 3/8z12	KT2K 1/2z14
a =	9mm	11,5mm
b =	20mm	21mm
c =	16mm	23mm
N =	27mm	43mm
T =	36,8mm	57,07mm

Powered conveyor roller with double chain wheel of thermoplastic material (KT2K 1/2z14,K,Fest) or of steel (KT2K 3/8z12,S,Fest / KT2K 1/2z14,S,Fest) with inserted conical elements.

Please find information on bearings with the corresponding gravity or powered conveyor roller.

**Fest = Fixed**

Pipe-Ø	Axle-Ø	Pipe design								Maximum load bearing capacity per roller*											
		S	SV	SG	SP	N	PG	PB	ALU	KT2K3/8z12,S			KT2K1/2z14,K			KT2K1/2z14,S					
										001	001N	005	021	021N	025	021	021N	025			
30x1	8	●	●			●				10	10	20									
50x1,5	10,12,14	●	●			●									40					80	
50x2,8	10,12,14						●	●						40	40	40			80	40	80

Chain wheel	Counter-bearing	Axle-Ø	EL =							
				IG	S	F	G	AG	BG	
KT2K 3/8z12	001/001N	8	RL +					64		0
	005	8	RL +					57		0
KT2K 1/2z14	021/021N	10,12,14	RL +	65						0
	025	10,12,14	RL +	65						0

\* - To determine the load bearing capacity of the axles and pipes, please use the chart on page 3.

Other designs upon request.

- - Design upon request
- - In the standard

Ordering example	KT2K 1/2z14,K,Fest 025-50x1,5 S A12 IG8x15, EL=566
------------------	---

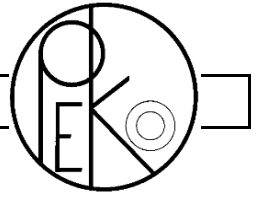



# Conical conveyor roller with belt grooves

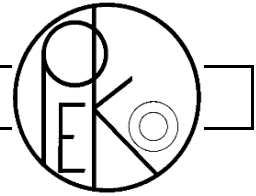

## KATS

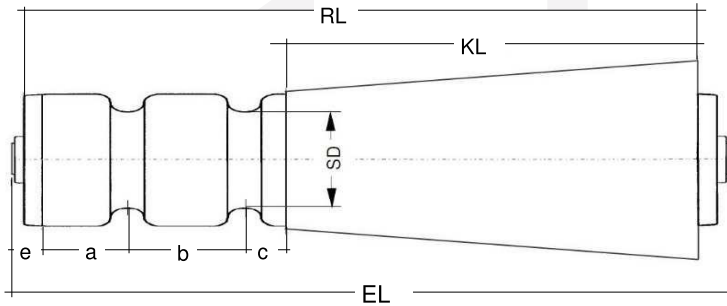

Belt groove conveyor roller with inserted conical elements of thermoplastic material.

Pipe-Ø	Axle-Ø	Pipe design				Belts-Ø		a+b	SD	c	Possible bearing	
		S	SV	N	PG	Minimum	Maximum					
50x1,5	10,SK11,12,14,15	●	●	●		5	30	30	120	40	10	025
50x1,5	10,SK11,12,14,15	●	●			6	30	30	120	38	10	025
50x2,8	10,SK11,12,14,15				●	5	30	30	97	40	10	025

Bearing	Pipe-Ø	Axle-Ø	S	SV	N	PG	Axle design						
							IG	S	F	G	AG	BG	
025		10					e = 8.5	8	8	8	13.5		
		SK11					e = 8.5	8	8	8			
		12					e = 8.5	8	8	8	14		
		14					e = 8.5	8	8	8	15.5		
		15*					e = 8	8	8	8			

			EL=							
025		10	RL+	12	11	11	11	22	12	
		SK11	RL+			11	11			
		12	RL+	12	11	11	11	23	12	
		14	RL+	12	11		11	26	12	
		15*	RL+	11	11				12	

\* Labyrinth loose

Other designs upon request.

- - Design upon request
- - In the standard

Ordering example

KATS/025-50x2,8PG A12 S8x6 EL=372  
- one-sided 2 belt grooves a=67, b=30, SD=40

# Conical conveyor roller with round belt drive, Ri=260mm

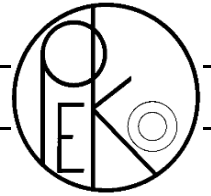

## KT2RR/049K,Fest

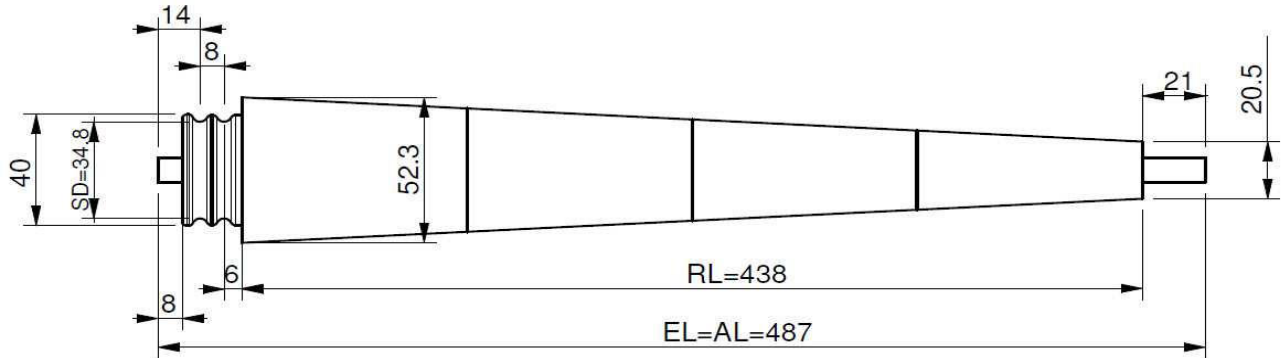

Powered conveyor roller with round belt wheel of thermoplastic material with inserted conical elements for internal radius  $R_i=260\text{mm}$ .  
 The grooved ball bearing 689ZZ is also available as 2RS (KT2RR/049K,RS,Fest) or INOX (KT2RR/049K,RSN,Fest).  
 Type 049K bearing seat of plastic.  
 Outside centre distance 57mm. Roller pitch  $4.5^\circ$ .

Internal-pipe-Ø	Axle-Ø	Pipe design			Belts-Ø	Maximum load bearing capacity per roller			
		S	SV	N		R	a	b	SD
17x1,5	9	●	●	●	5	14	8	34.8	4

Bearing	Pipe-Ø	Axle-Ø	EL=	Internal thread	Spanner flat	Spring axle	Smooth	External thread	Deposed external thread
				IG	S	F	G	AG	BG
049K	17x1.5	9	RL+	IG	S	F	G	AG	BG

Other designs upon request.

- - Design upon request
- - In the standard

Ordering example

KT2RR,K,Fest  
 049K-17x1.5S AN9 IG 6x10, EL=487

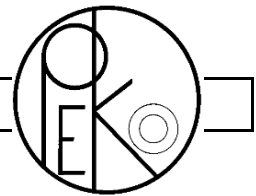

Guide discs

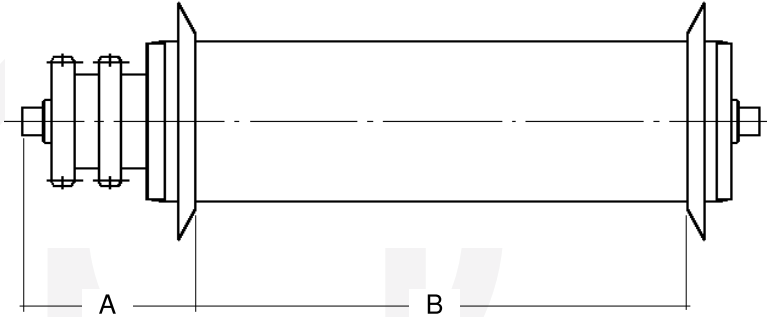

The masses of A and B must be specified when ordering conveyor rollers with guide discs.





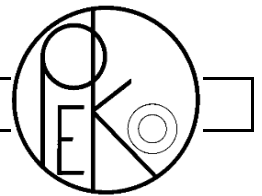

	d	D		d	D
	30	60		60	110
	40	60		120	130
	50	70		130	135
				140	
				150	
				88,9	130
					135
					140
					150
				108	160

Back up rings					Buffer rings				
	RD	D	d	b		RD	D	d	b
	63,5	108	60	25		50	89	48	30
	63,5	133	60	25		63,5	89	60	25
	88,9	133	85	30		63,5	108	60	30
	88,9	159	85	30		88,9	133	86	35
	108	159	104	30		88,9	159	86	35

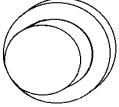
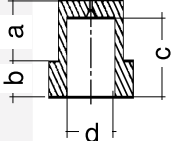
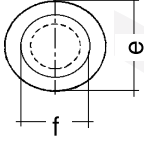
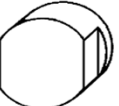
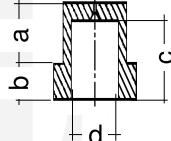
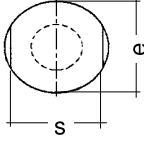
Other designs upon request.

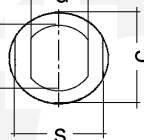
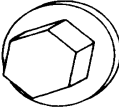
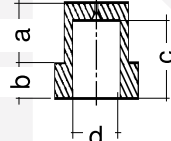
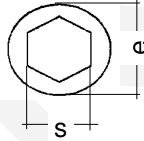
# Push-on caps

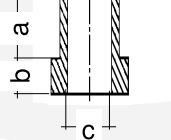
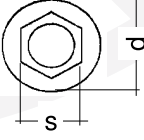

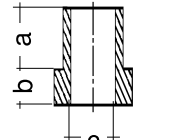
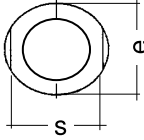
								
Order number	Axlediameter <b>AD</b>	a	b	c	d	e	f	
<b>K0</b>	15	9	5	11	15	28	20	A20 glatt/D=20
								
Order number	Axlediameter <b>AD</b>	s	a	b	c	d	e	
<b>K1</b>	8	10	10	5	12,8	8	12	SW 10x10/D=12
<b>K2</b>	8	14	10	5	12,8	8	16	SW 14x10/D=16
<b>K3</b>	10	14	10	5	12,8	10	16	SW 14x10/D=16
<b>K3.01</b>	10	12	9,5	5,5	13	10	16	SW 12x9.5/D=16
<b>K4</b>	12	14	10	5	12,8	12	16	SW 14x10/D=16
<b>K5</b>	14	17	10	5	12,8	14	21	SW 17x10/D=21
								
Order number	Axlediameter <b>AD</b>	s	a	b	c	d	e	
<b>K6</b>	20	30	13	3	36	15	20	SW 30x13/D=36
								
Order number	Axlediameter <b>AD</b>	s	a	b	c	d	e	
<b>K7</b>	8	11	17	2,5	19	8,5	18	SK 11x17
								
Order number	Axlediameter <b>AD</b>	s	a	b	c	d		
<b>K8</b>	8	11	11	2,5	7,8	18		SK 11x11
<b>K9</b>	8	11	11	2,5	8,5	18		SK 11x11 F
								
Order number	Axlediameter <b>AD</b>	s	a	b	c	e		
<b>K10</b>	10	12	8	2	9,8	16		SW 12x8/D=16

Push-on caps of thermoplastic material  
Other designs upon request.

Ordering example      A12 **K4** (Axle Ø12 uncoated, both side with push-on cap K4)

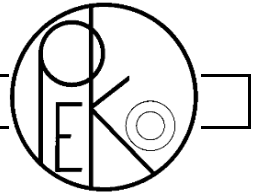

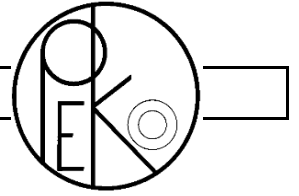

Mini rollers, ball bearing mounted and with hardened or plastic running surface  
Phosphatised surface

PEKO Article No.	Mini roller Dimensions	PEKO Article No.	Split mini roller Dimensions
MR-19/26 A6  C=1750N C0=1200N		SUMR-18/19 AG8x16 S10 sealed  C=1500N C0=1000N	
MR-19/26 A8  C=1100N C0=800N		SUMR-21/25 AG8x16 S10 Plastic cap POM natural	
MR-19/9 A6  C=1600N C0=1000N		SUMR-12/12 AG6x11.5 S7  C=800N C0=450N	
MR-18/16 A6  C=1250N C0=800N		SUMR-12/18 AG6x11 S7  C=800N C0=450N	
MR-12/16 A4  C=800N C0=450N		SUMR-18/19 AG8x16 S10  C=1500N C0=1000N	
MR-15/26 A6  C=1100N C0=750N		SUMR-15/25 AG6x11 S10  C=1200N C0=800N	
MR-24/26 A6 Plastic cap POM natural		<p><b>PEKO ROLLEN AG</b>                      Langenhagstrasse 13, CH-9424 Rheineck                      Tel.+41 71 888 08 44, Fax +41 71 888 08 47                      info@peko.ch / www.peko.ch</p>	

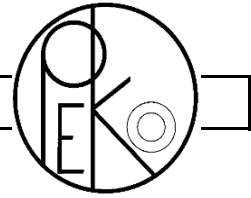

Conveyor wheels of thermoplastic material		Conveyor wheels of galvanised steel	
ST-065	ST-069	ST-073	ST-079

## Multi-directional rollers of thermoplastic material

ST-080		one piece			
		D	d	B	C
		40	8	26	29
		48	8	37	39
		60	8	47	48
		80	8	60	64
		120	12	86	90
ST-081		two pieces			
		D	d	B	C
		50	8	19,5	39
		60	8	25	51
80	8	30	60		

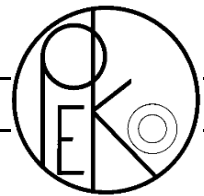

All roller tracks and guide tracks are available in fixed lengths according to your requirements (max. length 3000 mm). The wheels can be used in temperature ranges from -30°C to +100°C.

**Design with plain wheel:**

- Order no.: N 33 - length
- Order no.: N 50 - length
- Order no.: N 66 - length
- Order no.: N 83 - length
- Order no.: N 100 - length

**Design with flanged wheel:**

- Order no.: SP 50 - length
- Order no.: SP 66 - length
- Order no.: SP 83 - length
- Order no.: SP 100 - length

**The following special wheels are available:**

- a) Deep freeze design from -30°C
- b) Highly conductive wheel to prevent static charging (colour black).

If, with the fixed wheel track, a free dimensioning (S1 or S2) is to be in the front and rear, these dimensions must be specified. Your dimension specifications are our minimum dimensioning for the mounting. With flanged roller tracks, unequal free dimensions must be ordered for the right and left roller tracks. If you do not order free sizes the roller tracks are always to be mounted so that no wheel juts out. The wheel start varies, however, by the wheel pitch. If the wheels are to be started with exactly defined dimensioning, additional cut costs will be necessary.

**Special cut:**

Order no.: /SKF

**To order fix roller tracks:**

The pitches specified in the catalogue 33, 50 etc. are only approximate. The exact hole matrix in the fix wheel track is 16.667 mm +/- 0.1 mm.

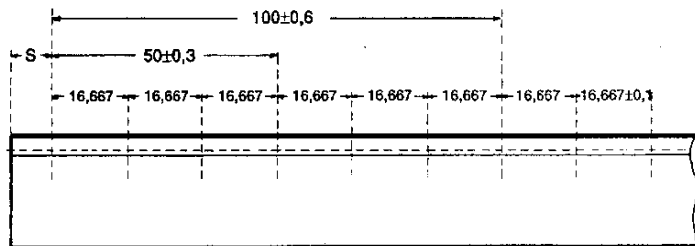
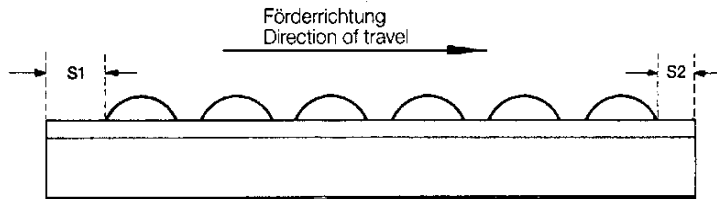
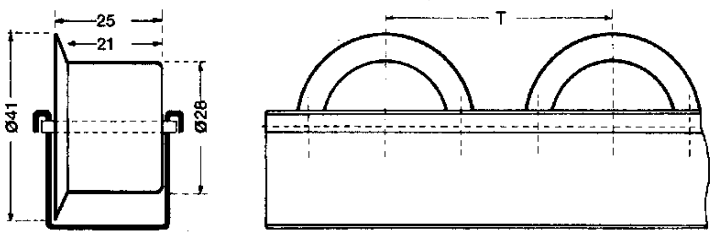
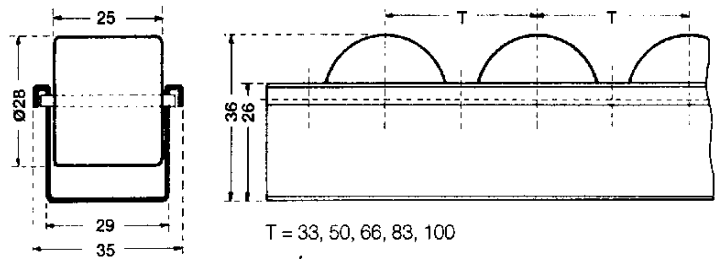

Fix-Röllchenleiste - Toleranzen  
Wheel channels - Tolerances

Please take the specified tolerances into account. If you would like to exactly specify the wheel start "S" (centre axle) (in connection with special cut order no.: /SKF), we can only comply with the exact dimension on this side. On the other side, you can only specify one size which, depending on the roller track length, phases out with the tolerances of the hole pitches (max. up to +/- 8.5 mm).

**Axle and profiles in stainless steel**

Order no.: (normal order no.)/VA

The axle can also be individually supplied in stainless steel. Order no.: AE

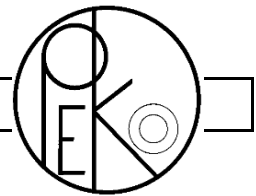

### Expansion lock:

The expansion lock consists of a specially bent and hardened spring steel wire with a diameter of 1.5 mm and prevents an expansion of the fix wheel track with greater loads. The lock is clamped in a free axle mounting.

Order no.: SpS

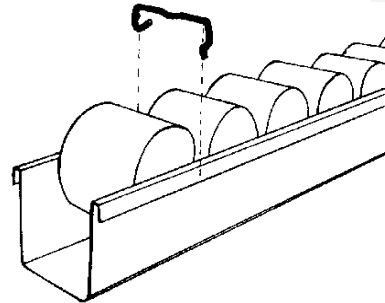
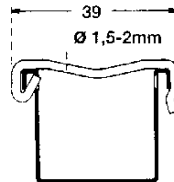

### Special designs of plain wheel:

Wheel highly conductive (wheel black)

Order no.: NHL-

Wheel colour black

Order no.: NSchw-

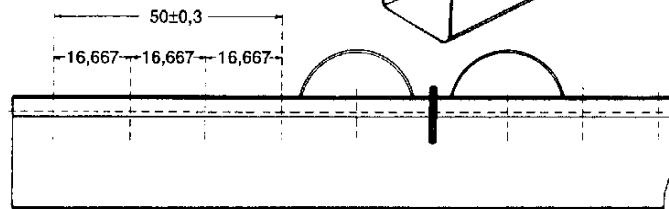

### Special designs of flanged wheel:

Wheel highly conductive (wheel black)

Order no.: SPHL-

Fix-Röllchenleiste mit Mininormalröllchen

T = 16, 33, 50

EUROROLL Wheel Channels. Mini Normal Wheels

T = 16, 33, 50

Fix roller tracks can be equipped with different wheels. In this way, all demands of the market and application are satisfied.

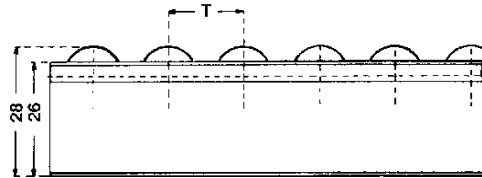
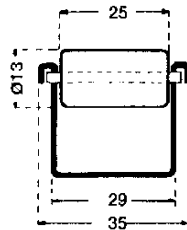

### Fix wheel track with mini normal wheels:

Order no.: N mini 16 - length

Order no.: N mini 33 - length

Order no.: N mini 50 - length

Also available in highly conductive design (black).

Fix-Röllchenleiste mit Minispurkranzröllchen

T = 33, 50, 66

EUROROLL Wheel Channels. Mini Flanged Wheels

T = 33, 50, 66

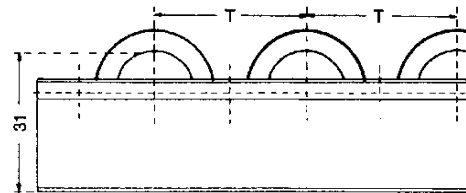
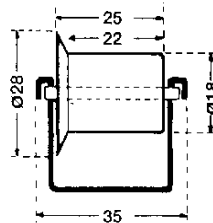

### Fix wheel track with mini flanged wheels:

Order no.: SP mini 33 - length

Order no.: SP mini 50 - length

Order no.: SP mini 66 - length

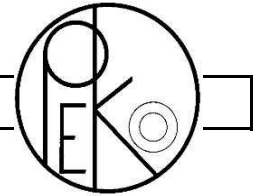

The main area of use of the superfix roller track is in flow racks for the secure running of heavy transport boxes and cartons. The wheels consist of high quality thermoplastic material which is impact and break-resistant. The material does not absorb moisture and is resistant to acids and lye. The wheels mounted on steel axles have a load capacity of 12 kg and are available as plain and flanged wheels. The roller track profile consists of cold-profiled, sendzimir galvanised steel profiles 1.5 mm thick.

All roller tracks are supplied in fixed lengths according to your wishes (max. length 3000 mm). Resistance torque  $W_y = 1.2 \text{ cm}^3$ .

### Design with plain wheel

#### Ordering example:

Order no.: SFN - (pitch) / length

Pitch:

33 mm SFN - 33 / length

50 mm SFN - 50 / length

66 mm SFN - 66 / length

100 mm SFN - 100 / length

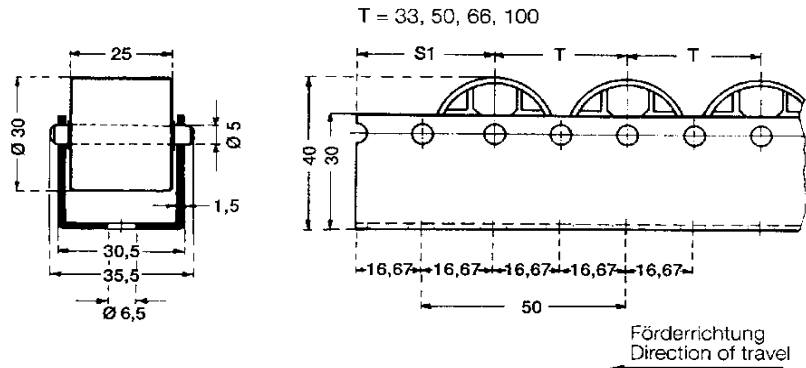

### Design with flanged wheel

#### Ordering example:

Order no.: SFSP - (pitch) / length

Pitch:

50 mm SFSP - 50 / length

66 mm SFSP - 66 / length

100 mm SFSP - 100 / length

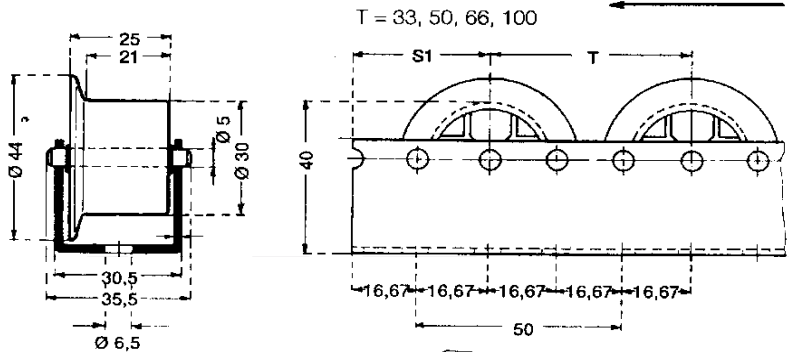

### Special cut:

Order no.: /SKSF

### Single wheels (incl. steel axles) Plain

roll:

Order no.: SFN

Flanged roll:

Order no.: SFSP

### Accessories

End stop:

Order no.: ESF

Loop delayed End stop:

Order no.: ESchESF

### Connector:

The connector consists of u- profiles which are mounted with 4 screws under the wheel track.

Order no. VSF

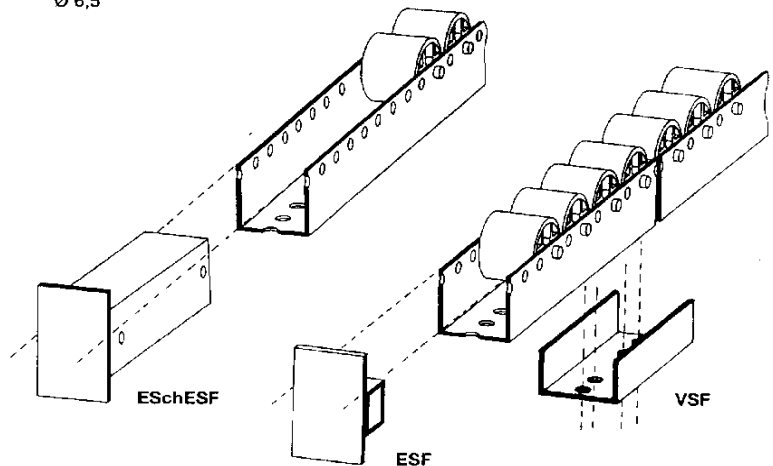

### To order the superfix-roller tracks:

Any length can be ordered. Try to order lengths in the hole matrix of 16.67 mm. Example: The last two digits of the length ordered should be 00, 16, 33, 50, 66, 83. Special cuts with defined wheel starts S1 are possible. For the installation in flow racks, free dimensioning is required. Please specify this in the order.

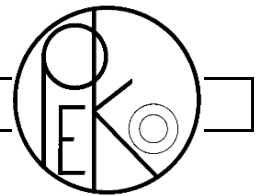

The bearing lengths of the universal roller tracks is 3000 mm. As a rule, we supply you with any desired fix length. The profiles is sendzimir galvanised,  $W_y = 2.2\text{cm}^3$ . Plain wheels are, if not specially ordered, mounted in the lower holes, flanged wheels are always mounted in the upper holes.

Universal-Rollenschiennenprofil  
Universal Roller Tracks Profile

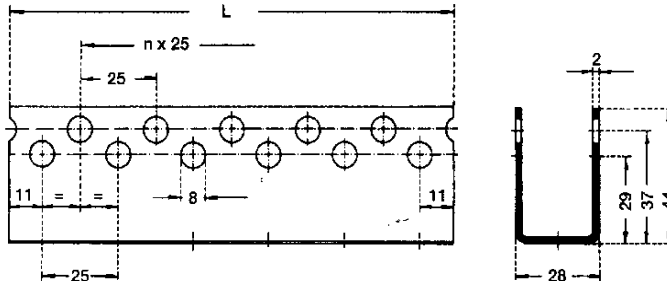

**Profiles without roll:**

Order no.: U28

**The following wheels are available:**

**ball bearing mounted:**

Plain roll,  $\varnothing 48$  mm, plastic

Payload 10 kg

Order no.: NR10

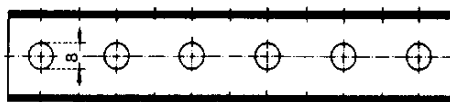

Plain roll, steel galvanised, Payload 20 kg

Order no.: NR20

Flanged roll, plastic, Payload 10 kg

Order no.: SR10

Flanged roll, steel, Payload 20 kg

Order no.: SR21

All plain wheels can be coated with a buffer ring of PUR. Order no.: PUR

Abmessungen Röllchen  
Dimension wheels

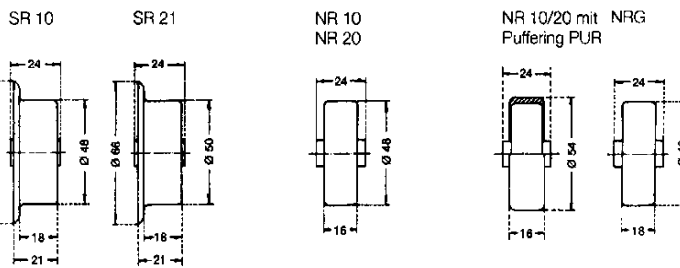

**Friction bearing:**

All friction bearing wheels have a minimum payload of 10 kg. The running surface of the friction bearing wheels is slightly spherical.

Plain roll, design polypropylene

colour: blue (hard plastic)

Order no.: NRGH

Plain roll, design PUR colour: yellow

(soft plastic)

Order no.: NRGW

The wheels NR10, NR20, SR10 and SR21 are mounted with tubular rivets and cover cap (rounded).

Order no.: HIN

Hauptabmessungen mit Kunststoff-Röllchen  
Main dimension with plastic wheels

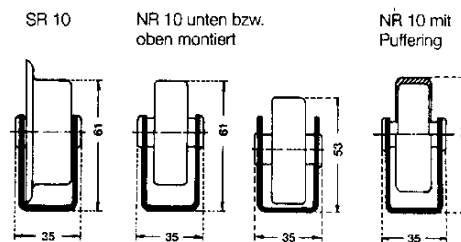

Hauptabmessungen mit Stahlröllchen  
Main dimension with steel wheels

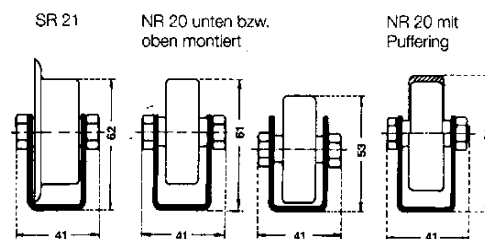

Upon request, they can be mounted with special plastic screws.

Order no.: VS 26

The wheels NRG are mounted with galvanised steel screws.

Order no.: M 8 X 35

All wheels can be individually exchanged.

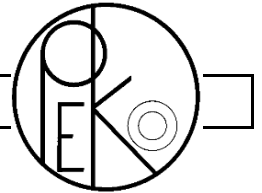

## Universal roller track with flanged wheel SR21

SR21 has, in contrast to SR20 roller which is no longer or only in limited quantities available, a diameter of 50 mm instead of 48 mm. With the parallel use of SR21 and NR20, the height difference of 1 mm must be aligned to the support points of the plain roller track.

### Ordering note:

Please specify the wheel type, the wheel pitch and the exact length (the length must be divisible by 25 mm) when ordering.

Ordering example: SR21 - 100/3000  
 Universal roller track with flanged steel wheels, 100 mm pitch, 3000 mm Total length

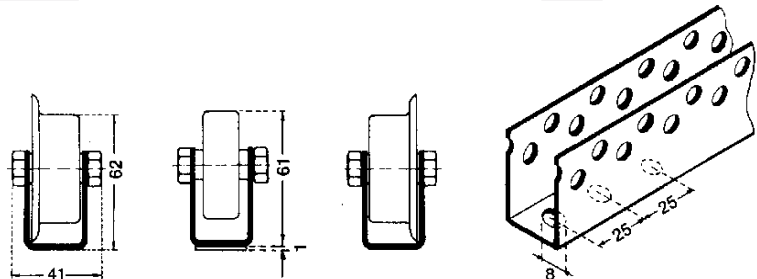

Please specify the wheel type, the wheel pitch and the exact length (the length must be divisible by 25 mm) when ordering.

Ordering example:  
 NR20 - 50/3000  
 Universal roller track with steel wheels, 50 mm pitch, 3000 mm Total length of the track

SR10 - 100/3000  
 Universal roller track with plastic wheels with flanges, 100 mm pitch, 3000 mm Total length of the track

### Accessories:

End stop:  
 Order no.: EU

Loop delayed end stop:  
 Order no.: EUS

Connector (incl. screws):  
 Order no.: VU

All wheels, screws, etc. can be individually ordered.

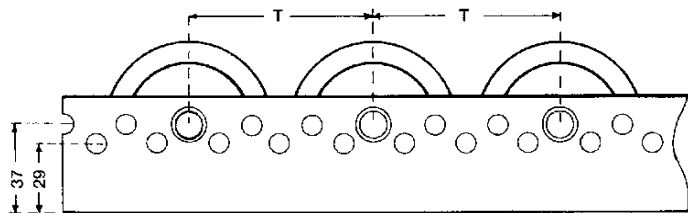

**Normalröllchen**  
**Plain wheels**  
 T= 50, 75, 100, 125, 150 usw.

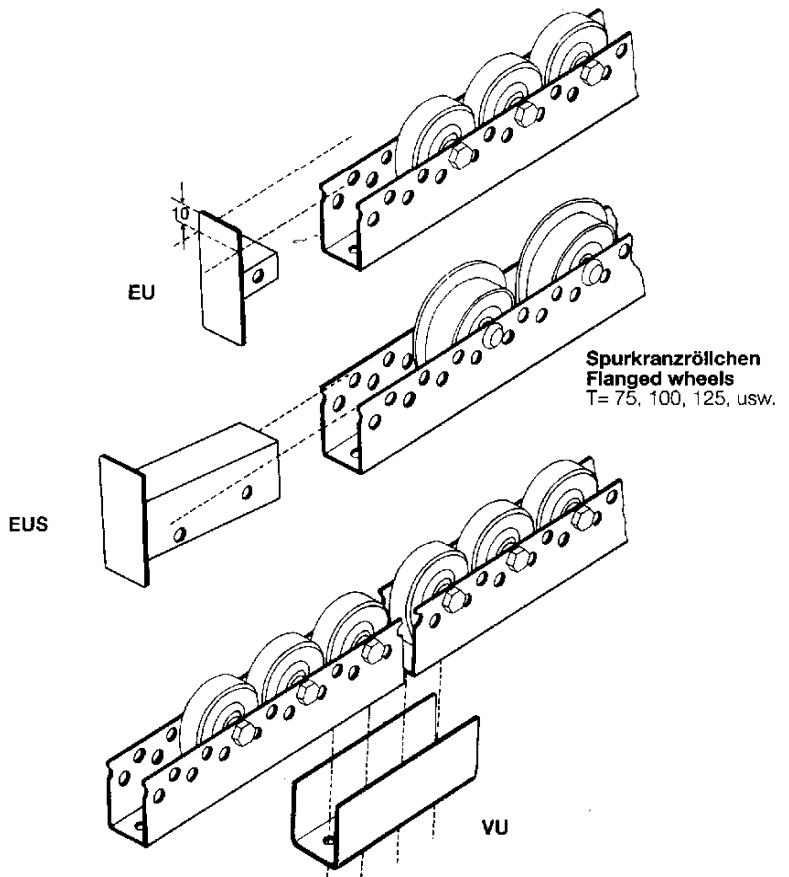

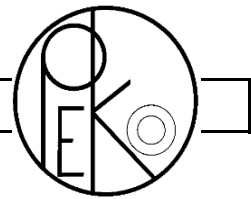

The Colli-roller track combines many advantages. It is the only solution for many logistic applications. In a sendzimir galvanised u-profile 50 x 58 x 50 x 2.5 mm, ball bearing mounted rollers are mounted exchangeably with a payload of 40 daN (kg). The roller  $\varnothing$  54 mm is available as a normal roller or as a flanged roller. Of course, both roller types can also be supplied interchangeably or e.g. only for every 4th roller with flange in the track. The roller coat is of plastic, colour blue, material polypropylene. The load capacity of a roller track is calculated from the resistance torque of 3.0 cm<sup>3</sup>. Through the wide running surface, the Colli-roller track expands the universal-roller track's application. The application areas listed for this also apply to the Colli-roller track.

Profiles without roll  
Order no.: U58

Plain wheel  $\varnothing$  54  
Order no.: NR40

Flanged wheel  $\varnothing$  70/54  
Order no.: SR40

Axle with lock nut  
Order no.: M 8 X 70

The bearing length of the Colli-roller track profile is 3000 mm. As a rule, we can supply you any desired fix length. Please observe that you must specify a linear measurement whose last two digits are 00, 33 or 66 (e.g. 2333 or 2300 or 2366 or 2400 mm). Other lengths require a special cut.  
Order no.: /SK

The following roller pitches are available: Plain roll: 66 mm, 100 mm, 133 mm, 166 mm, 200 mm. Flanged roll: 100 mm, 133 mm, 166 mm, 200 mm. Exchangeable flanged and normal roll: 66 mm, 100 mm, 133 mm, 166 mm, 200 mm.

Ordering examples:

SR 40-100/2000

Colli-roller track with flanged roll,  
100 mm roller pitch, 2000 mm long.

NR/SR 40-66/3333

Colli-roller track exchangeable with normal and flanged roll, 66 mm roller pitch, 3000 mm long.

Accessories:

End stop: Order no.: EC

Loop delayed end stop: Order no.: ESC

Roller protection: Order no.: RSC

Connector (incl. screws): Order no.: VUC

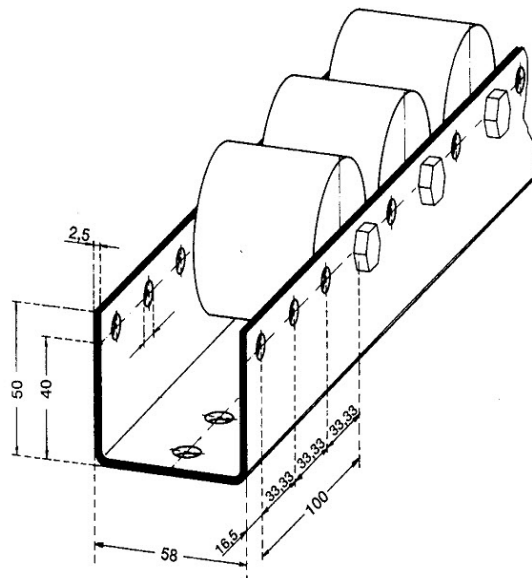
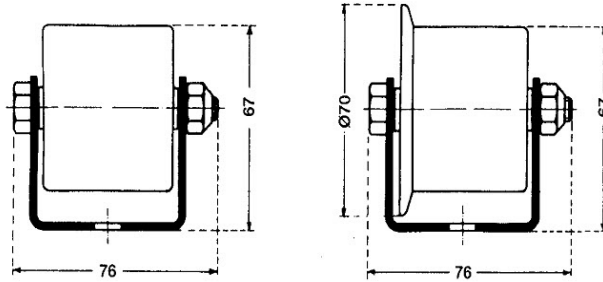
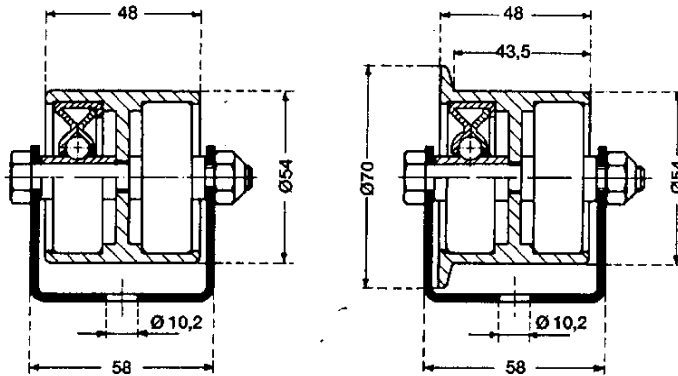

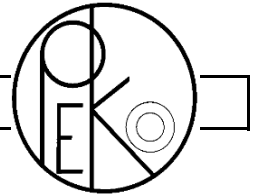

This multi-directional roller track is specified for light loads and is similar in design to the universal roller track. All accessories in this programme can be used such as e.g. end stop (Order no.: EU) or connector (Order no.: VU). The resistance torque of the roller track is 2.2 cm<sup>3</sup>. Load capacity per roller is 5 daN (kg). The bearing lengths of the Multi-directional roller tracks profil is 3000mm.

Ordering example:  
Order no.: AR 10 - (pitch) / length

Pitch:  
50 mm AR 10 - 50 / length  
75 mm AR 10 - 75 / length  
100 mm AR 10 - 100 / length  
125 mm AR 10 - 125 / length

Please specify if the roller is to be mounted in the upper hole  
Order no.: /0  
or in the lower hole  
Order no.: /U.

Single roller  
Order no.: AR 10

Order in a grid of 25 mm, all other lengths require a special cut.  
Order no.: SK

Suomi-multi-directional roller track for light loads  
Order no.: ASRS 50

The load capacity per roller is 10 daN (kg). This track is suited for a max. weight of goods to be conveyed of 100 daN (kg). The slight, lateral shift or rotation of conveyed goods requires a tight roller gap in both directions. This must be determined by tests if necessary. The resistance torque of the roller track is 2.2 cm<sup>3</sup>.

Ordering example:  
Order no.: ASRS 50 - (pitch) / length

Pitch  
66 mm ASRS 50 - 66 /length  
100 mm ASRS 50 - 100 /length  
133 mm ASRS 50 - 133 /length  
166 mm ASRS 50 - 166 /length

Single roller  
Order no.: ASR 50

Accessory:  
End stop  
Order no.: EA 50

**Universal Allseitenrollenschiene  
Multi-Directional Wheel Channel  
AR 10**

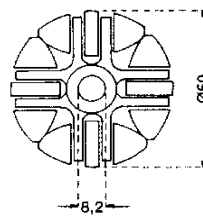

Rolle montiert in unterer Lochreihe  
Wheel mounted in lower hole

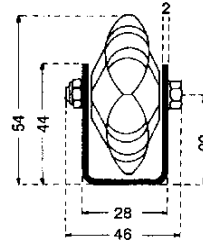

Rolle montiert in oberer Lochreihe  
Wheel mounted in upper hole

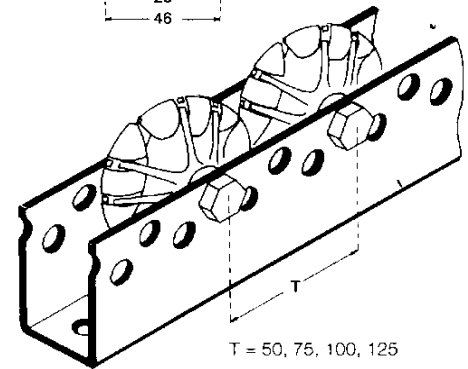
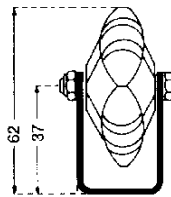

**ASRS 50**

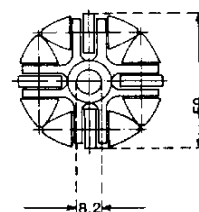
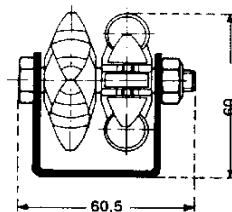
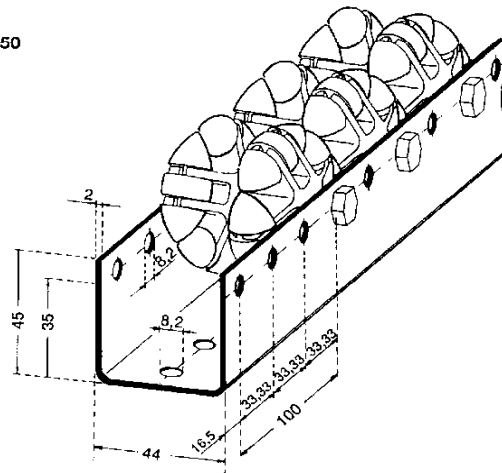

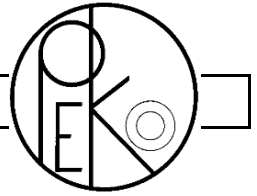

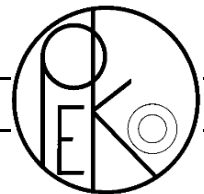

The roller tracks consist of one sendzimir galvanised u-profiles, 55 mm high and 80 mm wide. These profiles are equipped with rollers, Ø 50 mm, or rolls Ø 48 mm, in pitches of 52, 78, 104, 130, 156 mm etc. Two other rows of holes in the floor are used for mounting this track on bases.

Wy: 4.6 cm<sup>3</sup>  
ly: 17 cm<sup>3</sup>  
Length: 3000 mm

Track without rollers:  
Order no.: U 80 - 55

The pallet roller track can be equipped with various rollers.

3 normal rolls of plastic  
(30 kg load capacity)  
Order no.: NR 30

3 normal rolls of steel  
(60 kg load capacity)  
Order no.: NR 60

Steel rollers with 150 kg load capacity:  
Order no.: NR 100

Steel rollers with flange:  
Order no.: SR 100

The rolls and rollers are positioned on an axle with lock nuts  
Order no.: M 8 X 90 A

Abbreviations for orders:  
NR 100 (60) (30) = Type designation of the roller track

-52, -78, -104, -156 etc. roller pitch/2600  
length of the roller track (the length should be divisible by 26 mm)

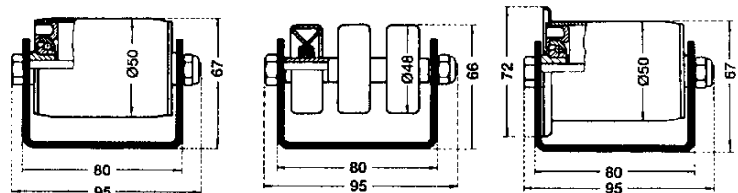

NR 100

NR 30 und NR 60  
NR 30 and NR 60

SR 100

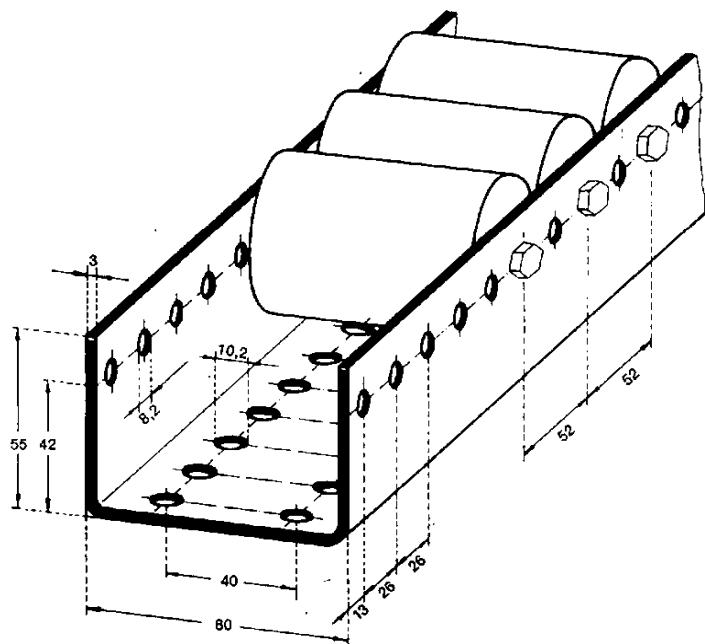

Rollenteilung: 52, 78, 104, 130, 156  
Roller pitches: 52, 78, 104, 130, 156 a.s.o.

#### Accessories:

End stop: Order no.: EE  
Sliding end stop: Order no.: ESchE  
Connector as u-profile: Order no.: VE  
Roller protection: Order no.: RSE  
Lateral connection pieces (2 pieces): Order no.: USE Fixing  
clip with screw: Order no.: BKE

#### Example:

NR 100 - 156 / 2600 roller track with Ø.50 mm steel rollers in 156 mm pitch, track: 2600 mm long.

The mounting with flanged rollers can be done so that e.g. only every 5th roller is mounted with a flange.

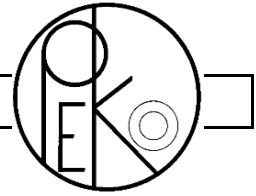

Brake rollers regulate the speed on gravity roller conveyors; they keep the goods being conveyed at a constant shunting speed. This is done using a planetary gear which presses centrifugal brake shoes on the roller with each rotation and this, with proportional braking force to the applied braking torque. The distance of the brake rollers and the right brake roller type are influenced by several factors:

- a) Design and functional performance of the roller conveyor
- b) Incline of the roller conveyor
- c) Behaviour of the goods being conveyed (size, weight, sensitivity, runner material)
- d) Inherent resistance of brake roller
- e) Environmental influences such as moisture, cold or heat.

One brake roller per pallet position is ideal because this is the only way, a controlled speed can be achieved without accelerations and the occurrence of increased forces. The shunting speed should never exceed 0.3 m/sec. if the brake rollers are correctly aligned, they it is only 0.1 – 0.2 m/sec.

The brake roller is available with a short or long holder.  
Order no.: -K or -L

With 4% incline, it is available for the following maximum braking payloads:  
300 kg Order no.: EBR 300 - (Holder)  
500 kg Order no.: EBR 500 - (Holder)  
800 kg Order no.: EBR 800 - (Holder)  
1000 kg Order no.: EBR 1000 - (Holder)  
1200 kg Order no.: EBR 1200 - (Holder)

Ordering example:  
EBR 800 – L  
Brake roller with long holder for  
800 kg/pallet

Support axle for mounting the  
brake roller  
Order no.: AAB

Spring suspension in various lengths  
A = 30 Order no.: FB 30  
A = 40 Order no.: FB 40  
A = 50 Order no.: FB 50  
A = 65 Order no.: FB 65

Clip bolts in various lengths  
H = 67 Order no.: HB 67  
H = 88 Order no.: HB 88

Brake lining for the conveyor roller with  
indirect use  
(Please give length L) Order no.: RNN - L

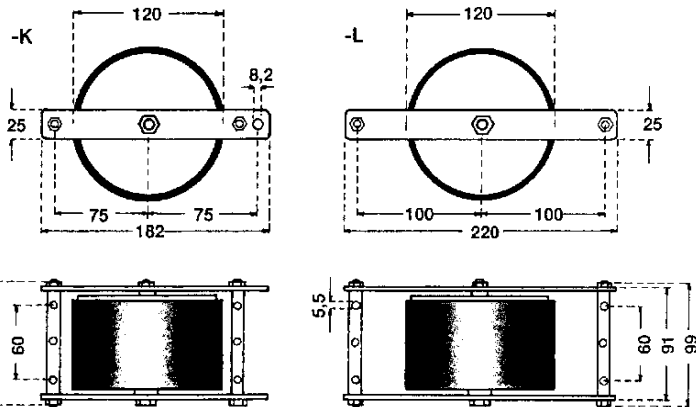

Aufhängeachse  
Support axle

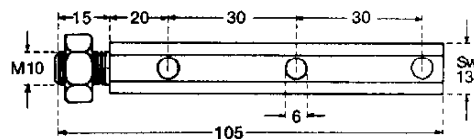

Federaufhängung  
Spring suspension  
A = 30, 40, 50, 65

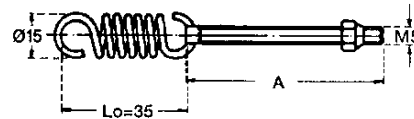

Hakenschraube H = 67, 88 mm  
Hook screw H = 67, 88 mm

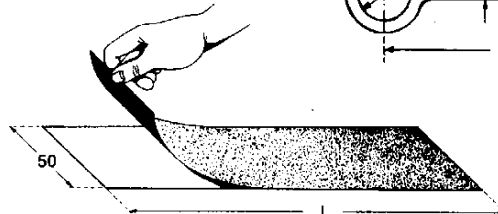
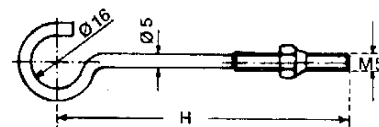

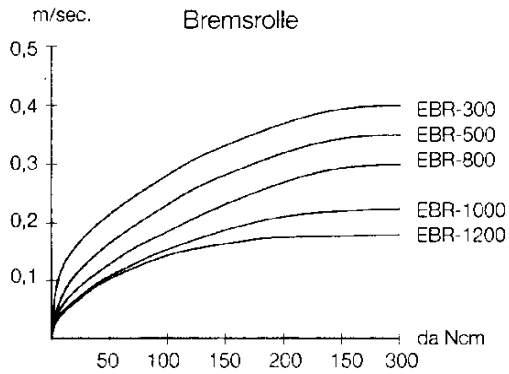
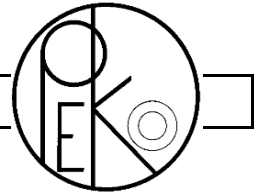

Braking force diagram for the right selection of the correct brake roller. Forces (which mainly result from acceleration) which exceed those in this diagram can destroy the brake roller and are therefore not permitted.

### Direct deceleration:

With direct deceleration, the brake roller has direct contact to the goods being transported. It is suspended elastically and must be approx. 2 mm above the level.

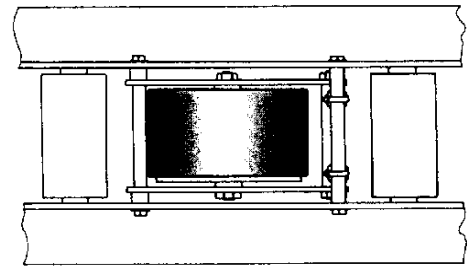
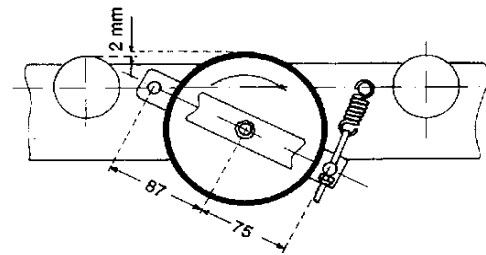

### Indirect deceleration:

Indirect deceleration is preferred in many cases because the contact to the pallet is transferred via 2 conveyor rollers. 4 springs take over the contact, 2 clip bolts, which are loosely installed, secure the brake rollers.

In order to improve the contact of the brake roller, conveyor roller and pallet, a self-adhesive friction lining is provided on the conveyor roller in the area of the brake roller.

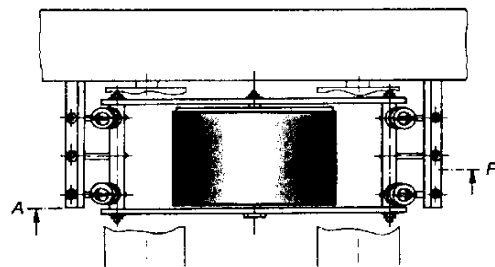
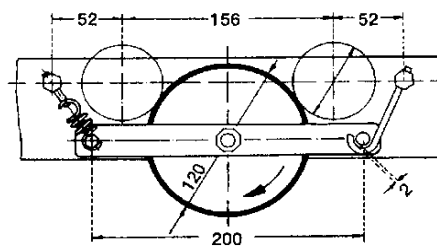

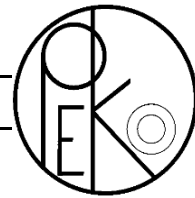

The **PEKO clutch brake system KB1512** was specially developed for the transport of boxes, containers and cartons up to a weight of 40kg. Since it is an open system, no malfunction will occur due to pollution caused by abrasion. A simple function and wear control from the outside is possible. Due to very high wear resistance, many millions of switching cycles with high drive and braking torque are possible.

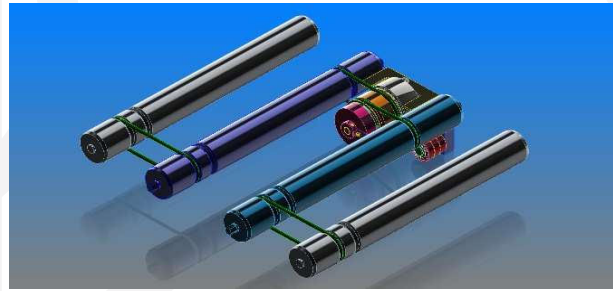
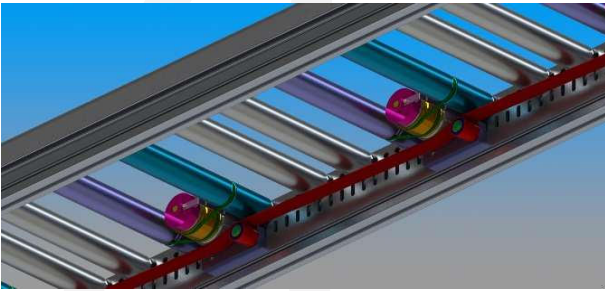

## **Clutch brake system:**

### **Scope of delivery consists of:**

- 1 unit clutch/brake incl. adapter plates and belt deflection wheel
- 1 unit sheet metal frame for cable attachment
- 1 unit clamping sheet (against hole pitch in side profile)
- 1 four-pole plug MKF 13264-6-0-404 AWG 24 Stocko (other design is possible)
- 4 conveyor rollers  $\text{Ø}50 \times 1.5$  (uncoated, galvanised or Niro), variable length
- 2 round belts  $\text{Ø}5$  L=302mm (at p=75)
- 2 round belts  $\text{Ø}5$  L=361mm (at p=125)
- Screws for mounting

Profile, control and drive are not part of scope of delivery!

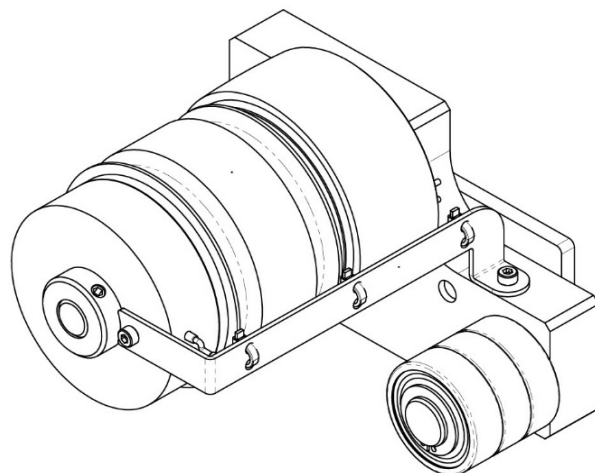

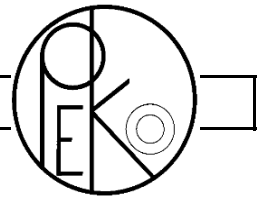

## Technical data:

### Clutch:

Mechanical power	15 W
Nominal torque	4.5 Nm
Nominal voltage	24 V DC

### Brake:

Mechanical power	12W
Nominal torque	4.5 Nm
Nominal voltage	24 V DC

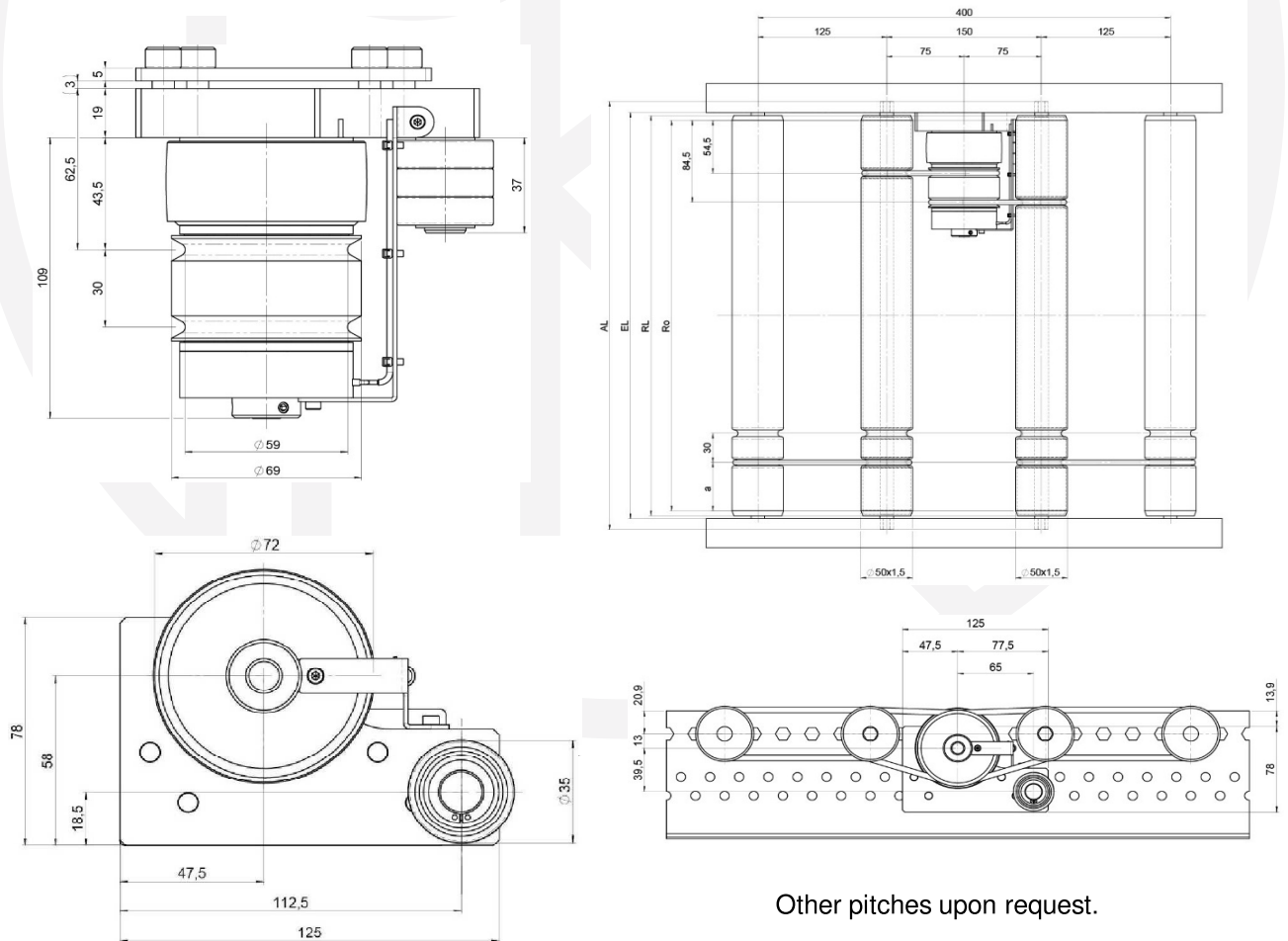

Other pitches upon request.

The clutch brake system is to be driven by means of an endless flat belt b=25mm

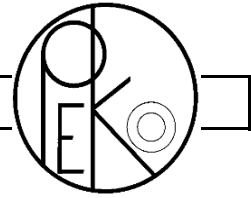

Gravity conveyor roller with smooth axle (G) or spring axle (F)

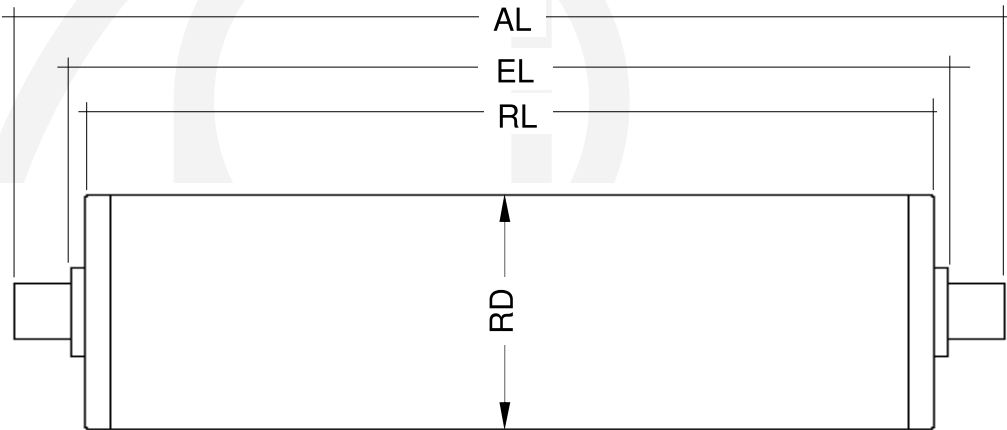

Gravity conveyor roller with external thread (AG)

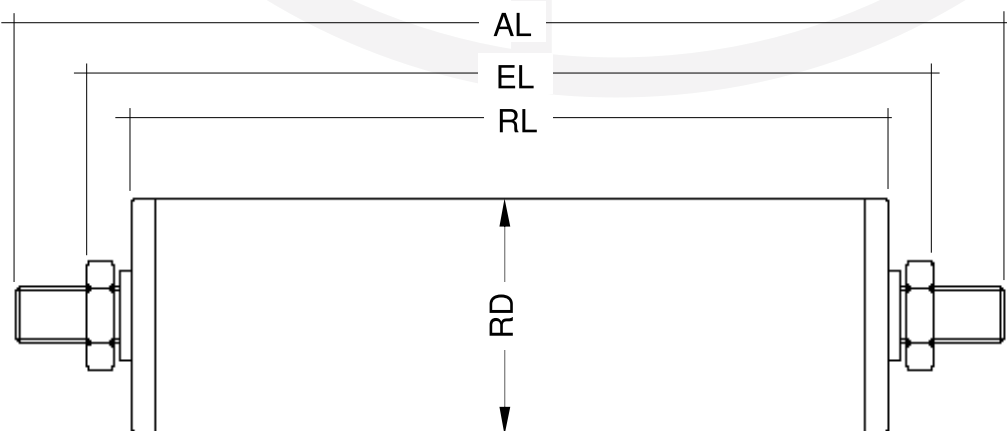

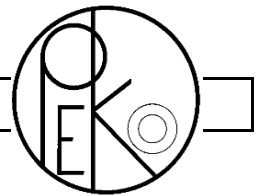

Gravity conveyor roller with internal thread (IG)

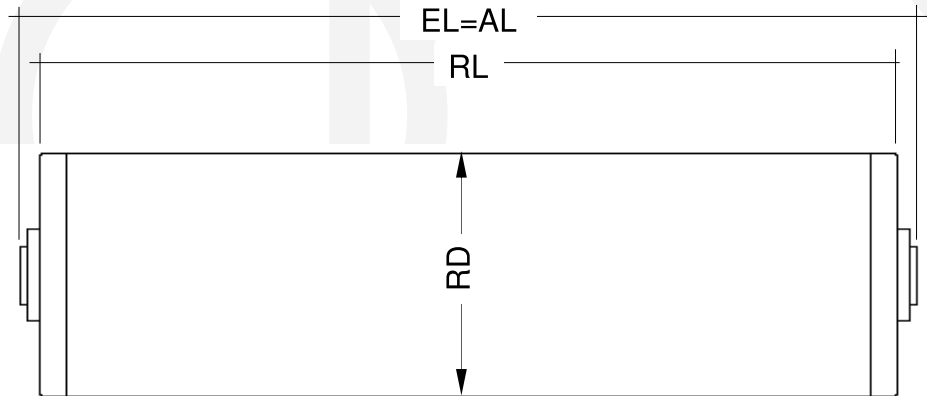

Gravity conveyor roller with spanner flat (S)

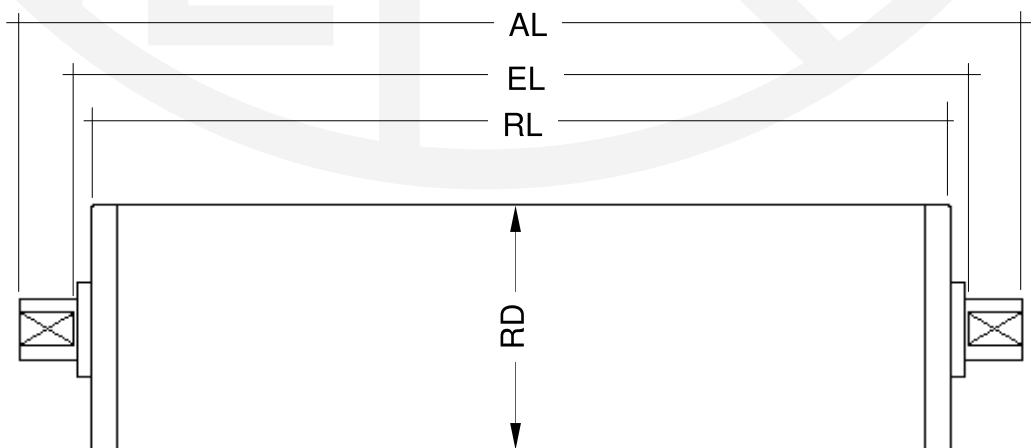

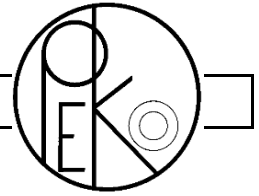

Powered conveyor roller with belt grooves and internal thread (IG)

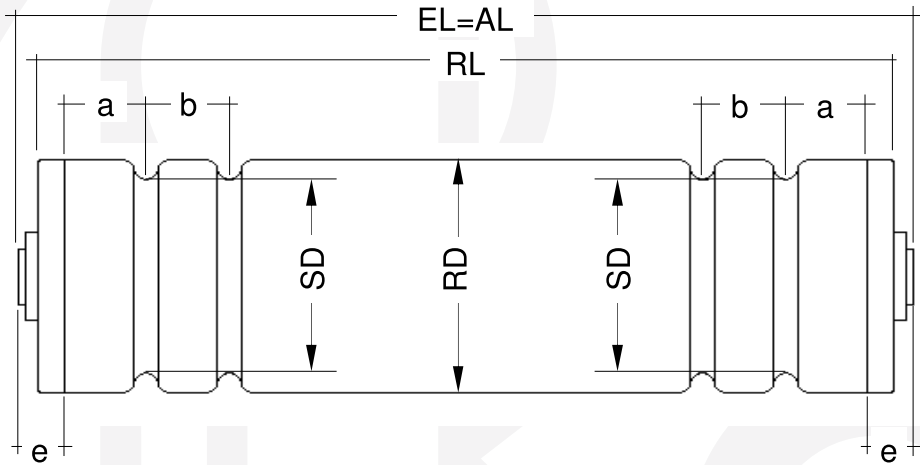

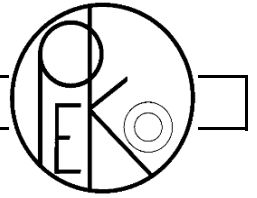

Powered conveyor roller  
with tooth belt wheel and internal thread (IG)

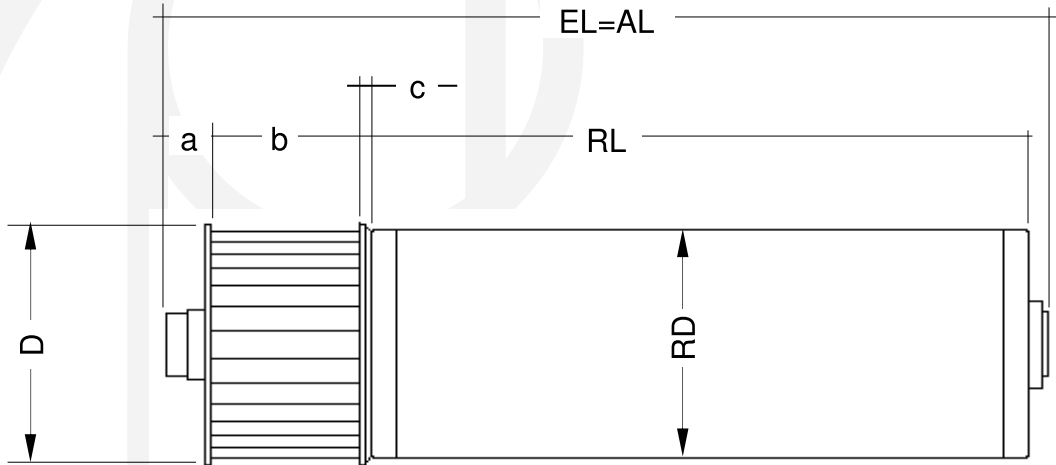

Powered conveyor roller  
with doubled tooth belt wheel and internal thread (IG)

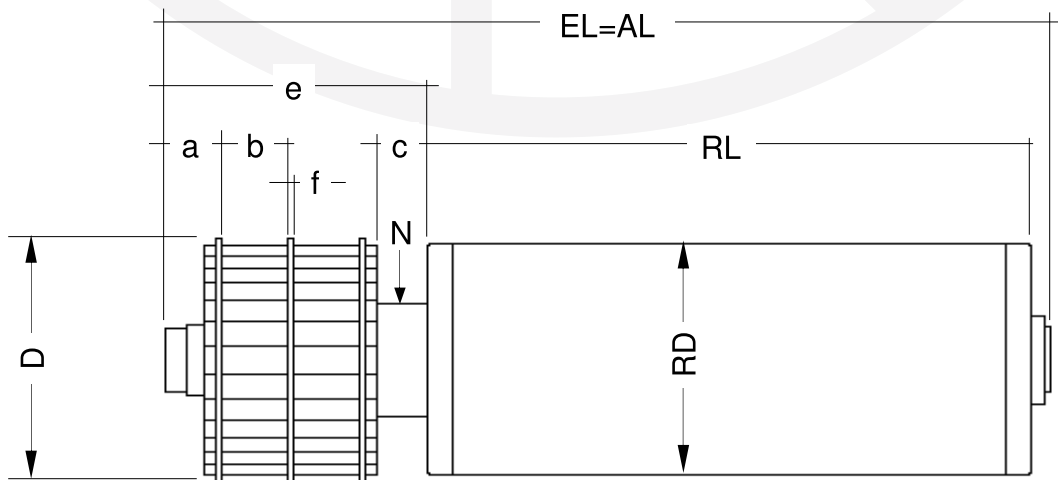

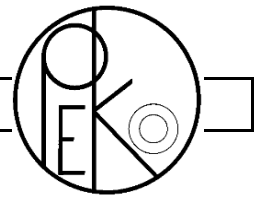

Powered conveyor roller  
with single chain wheel and internal thread (IG)

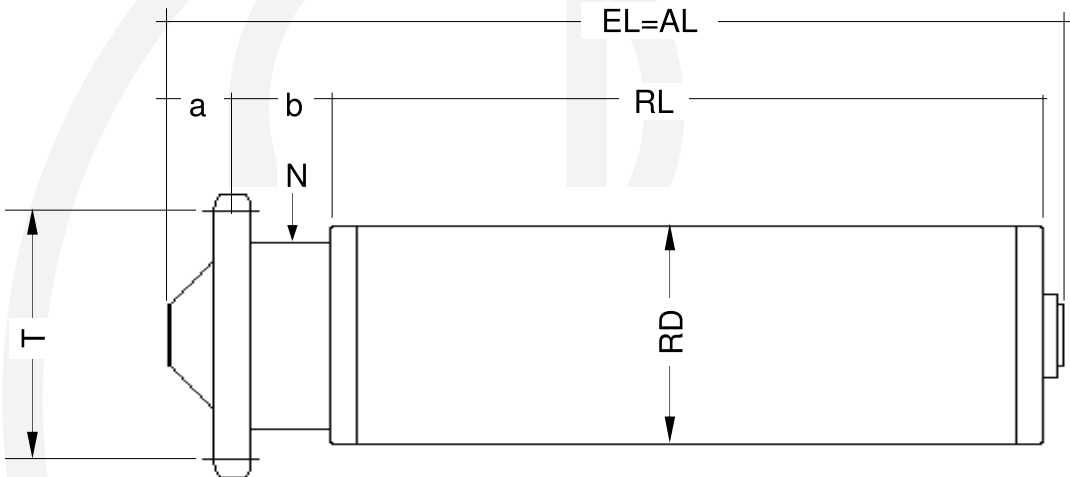

Powered conveyor roller  
with single chain wheel and external thread (AG)

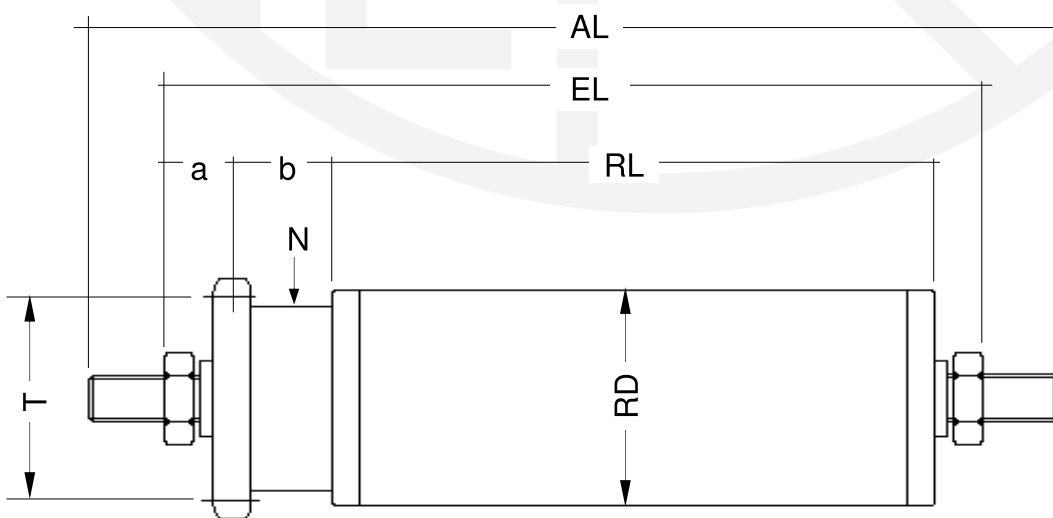

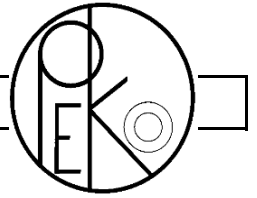

Powered conveyor roller  
with double chain wheel and internal thread (IG)

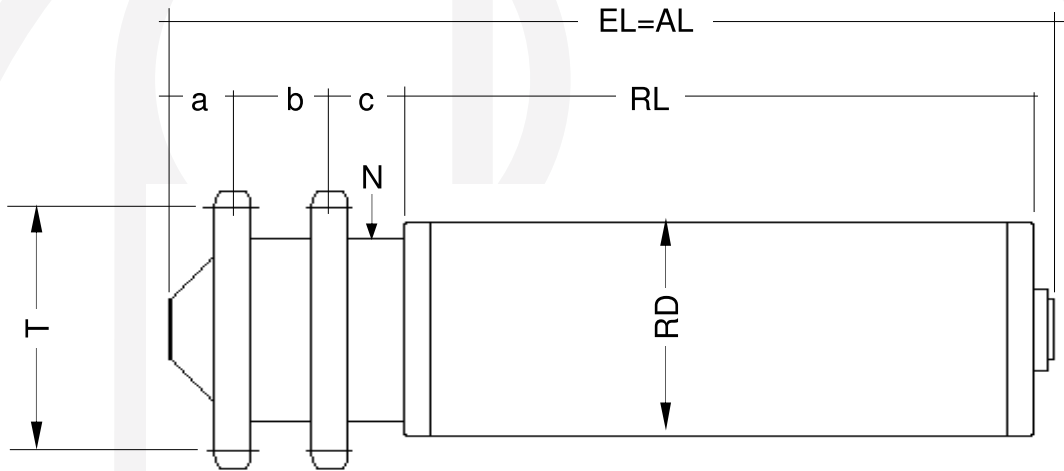

Powered conveyor roller  
with double chain wheel and external thread (AG)

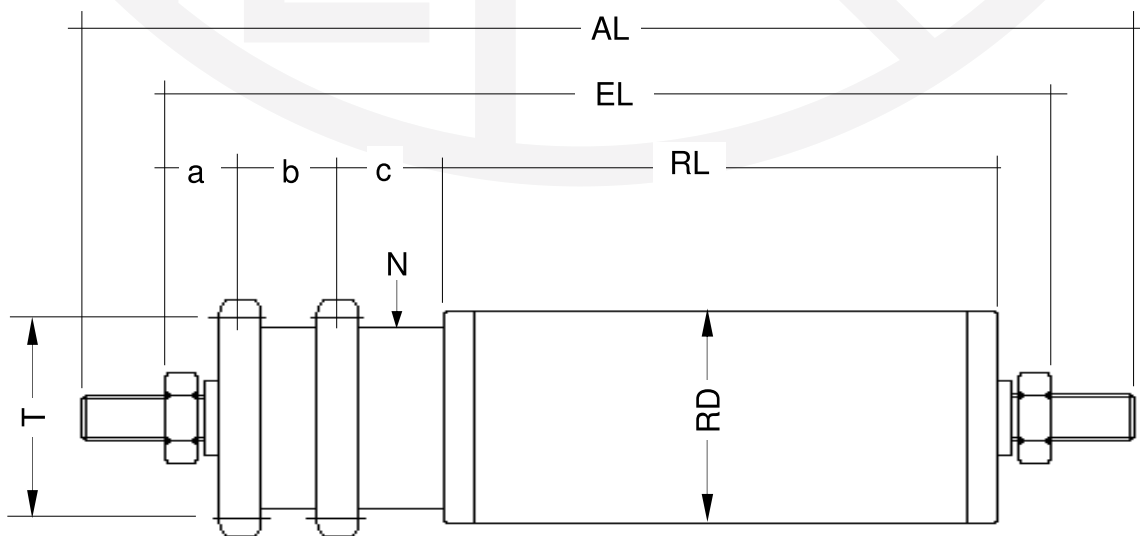

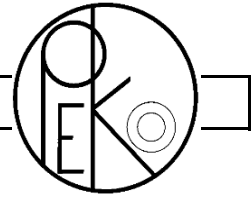

Conical gravity conveyor roller  
with inside thread (IG)

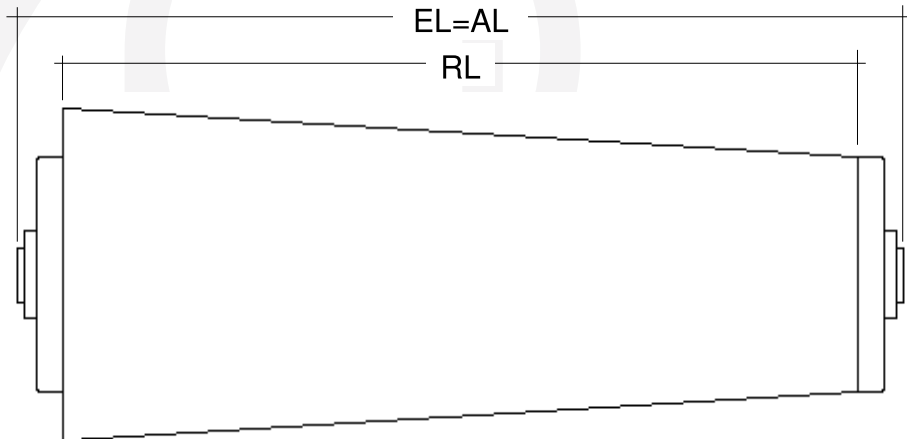

Conical Gravity conveyor  
roller with spanner flat (S)

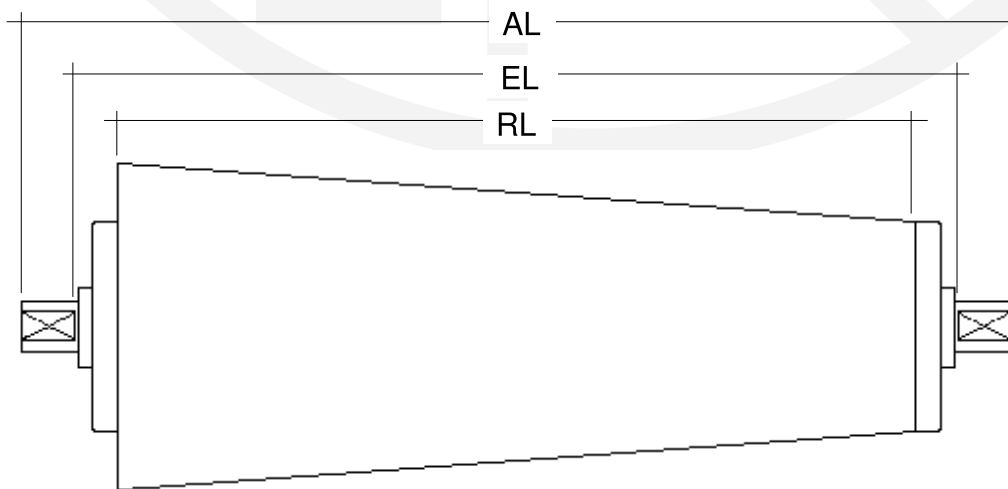

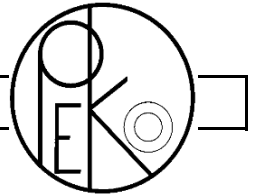

Conical gravity conveyor roller  
with smooth axle (G) or spring axle (F)

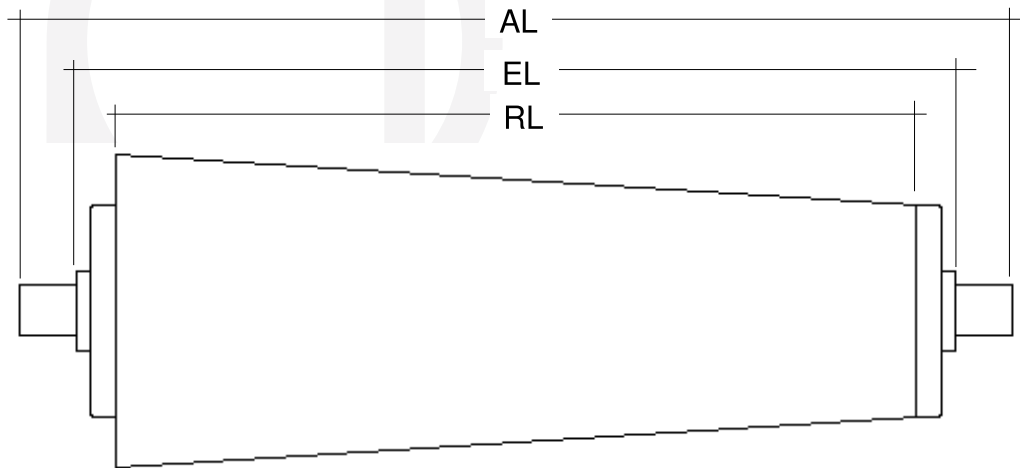

Conical gravity conveyor roller with external thread (AG)

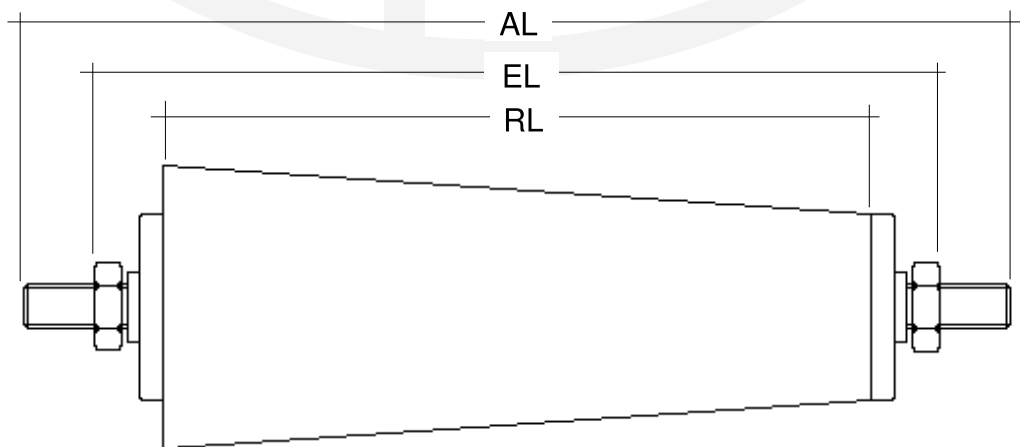

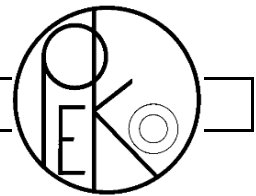

Conical conveyor roller  
with single chain wheel and internal thread (IG)

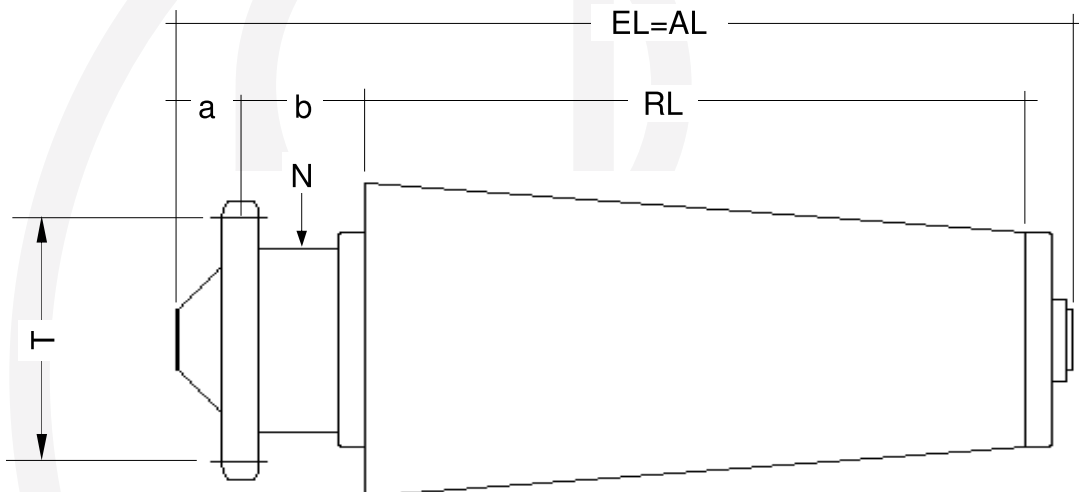

Conical conveyor roller  
with single chain wheel und external thread (AG)

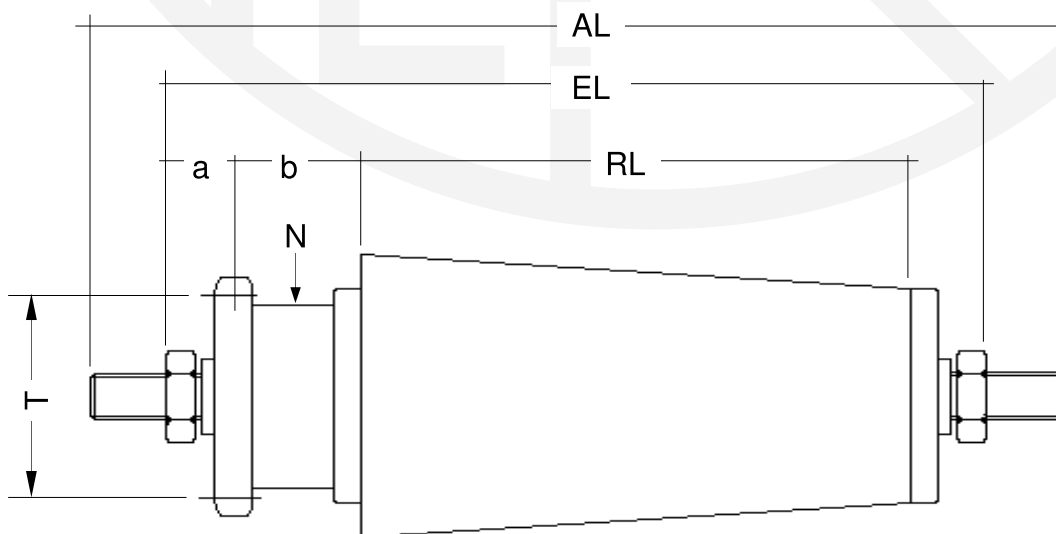

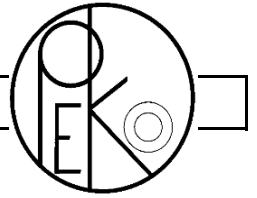

Conical conveyor roller  
with double chain wheel and internal thread (IG)

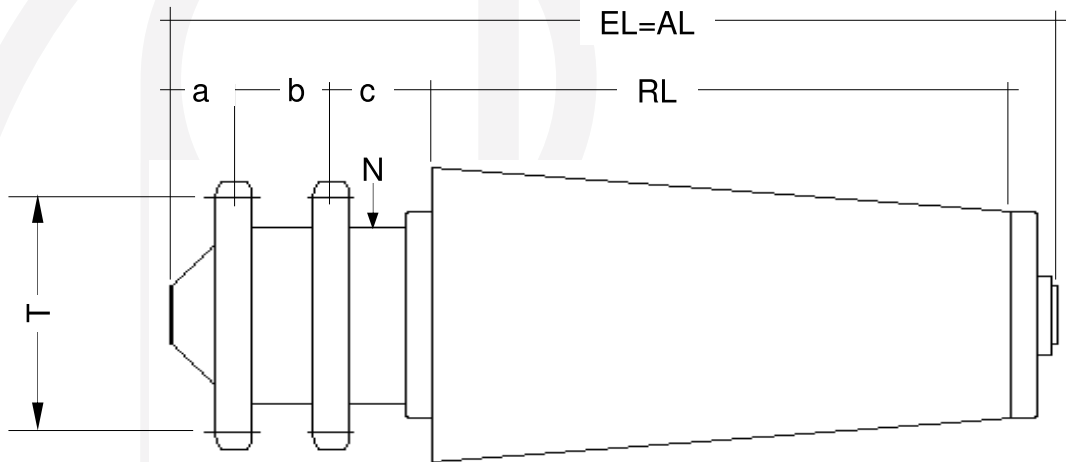

Conical Conveyor roller  
with double chain wheel und external thread (AG)

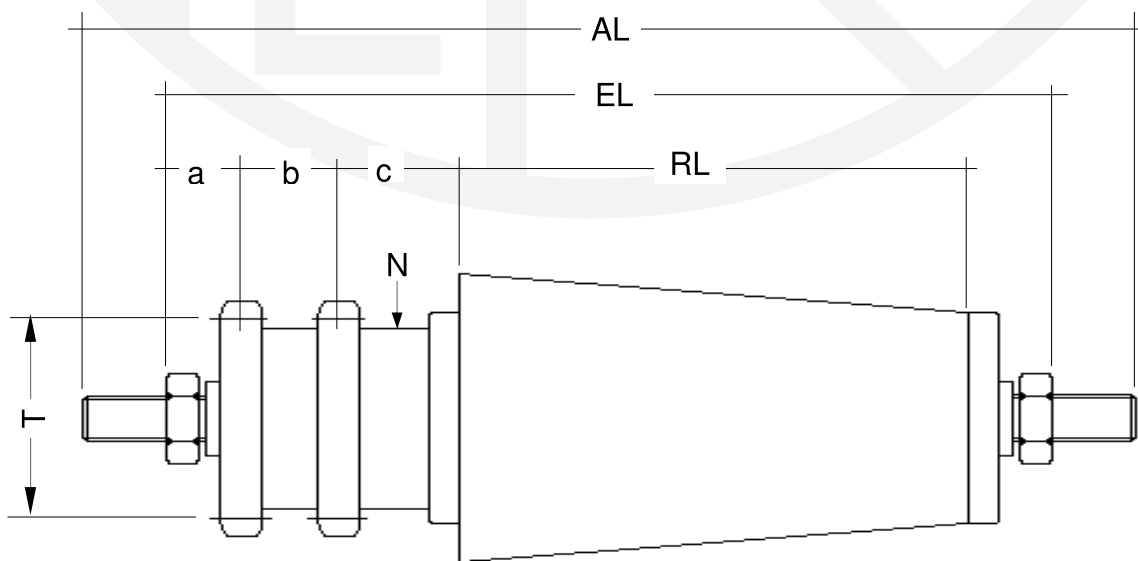

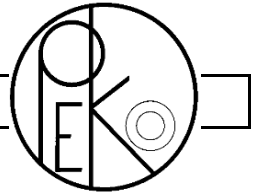

# PEKO inquiry form

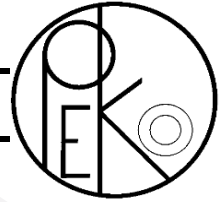

Company:	Name:
Tel.:	Fax:
E-Mail:	

Gravity conveyor roller   
 Powered conveyor roller

Quantity: \_\_\_\_\_ piece  
 Load/Roller: \_\_\_\_\_ kg

If known PEKO type: \_\_\_\_\_

Roller length RL: \_\_\_\_\_ mm    Installation length EL: \_\_\_\_\_ mm    Axle length AL: \_\_\_\_\_ mm

### Material data:

Pipe Ø	Wall thickness	Pipe material	Axle Ø	Axle design	Bearing type
16	1	steel uncoated	6	Internal thread <input type="checkbox"/>	Plastic with row of balls: Steel balls <input type="checkbox"/> Niro balls <input type="checkbox"/>
20	1.5	steel galvanised	8	IG _____ x _____	
30	1.8	Niro 1.4301	10	External thread <input type="checkbox"/>	Plastic with grooved ball bearing: ZZ <input type="checkbox"/> RS <input type="checkbox"/> RSN <input type="checkbox"/>
40	2	PVC blue	SK11	AG _____ x _____	
50	2.3	PVC gray	12	Spanner flat <input type="checkbox"/>	Sheet steel with cone bearing <input type="checkbox"/>
60	2.8	ALU	14	SW _____ x _____	Steel with grooved ball bearing: ZZ <input type="checkbox"/> RS <input type="checkbox"/> RSN <input type="checkbox"/>
63	2.9		15	Spring axle <input type="checkbox"/>	
63.5	3		17	Smooth axle <input type="checkbox"/>	
70	3.6		20		
80	4		25	rubber coating	PVC tube
88.9	4.5		30	Thickness _____ mm	2mm
101.6				Hardness Shore _____	3mm
108				Axle material	5mm
133				steel uncoated <input type="checkbox"/>	
159				steel galvanised <input type="checkbox"/>	
				Niro 1.4305 <input type="checkbox"/>	

### Drive data:

Chain wheel

Round belt groove

Single chain wheel: steel <input type="checkbox"/> plastic <input type="checkbox"/>	Fixed drive <input type="checkbox"/>	3/8 <input type="checkbox"/>	AE-MK(a):	groove Ø _____	measure a
	Accumulation drive <input type="checkbox"/>	1/2 <input type="checkbox"/>	MK-MK(b):		measure b
Double chain wheel: steel <input type="checkbox"/> plastic <input type="checkbox"/>	Adjustable <input type="checkbox"/>	5/8 <input type="checkbox"/>	MK-RL(c):		measure c
	Welded <input type="checkbox"/>	3/4 <input type="checkbox"/>			
				Number of teeth _____	

Tooth belt wheel

Poly-Chain 8M	Fixed drive <input type="checkbox"/>
	Accumulation drive <input type="checkbox"/>
	Welded <input type="checkbox"/>
	Number of teeth _____

Accessories:	Quantity	External Ø
Flanged wheel <input type="checkbox"/>		
Buffer Ring <input type="checkbox"/>		
Support ring <input type="checkbox"/>		
Con. Elements <input type="checkbox"/>		

Ribbed belt



### **General**

These terms and conditions apply to all legal matters between us and our clients. They are deemed accepted upon order placement. Deviating purchasing terms and conditions shall not be binding even if we do not expressly object to them.

Our contracting representatives are not authorized to modify the pre-formulated contract text or the additional verbal agreements verbally or by telephone.

All technical data set forth in the catalogue and drawings is approximate in value and non-binding.

### **Offers**

Our offers are without obligation and non-binding. We reserve our unrestricted property rights and copyrights for all drawings, sketches, samples which are enclosed with the offers. They may not be made accessible to third parties and are to be sent back to us immediately on demand.

### **Dispatch**

According to Incoterms 2010. Unless otherwise agreed delivery risk and cost are the recipient's responsibility in any case.

In the absence of shipping instructions from the customer, shipping will be done at our discretion in the most cost-effective manner.

Costs for packaging are calculated at cost price and used packaging returns are not accepted.

### **Delivery**

Our delivery is done as soon as possible. The delivery period shall be extended to an appropriate extent in the event of measures within the scope of lawful industrial disputes, in particular strikes lock-outs as well as the occurrence of unforeseeable obstacles, which are beyond our control in so far as such obstacles demonstrably have a considerable influence on the delivery of the item. This also applies, if the circumstances arise with sub-contractors.

We are also not to answer for the above mentioned circumstances, if they arise during an already existing delay. The beginning and end of such obstacles are in serious cases to be notified by us to the customer. The customer is only entitled to rescission of the contract after setting an appropriate period of grace. If orders placed are withdrawn or annulled the customer is obligated to so accept and pay for any initiated production quantities produced to this date.

Call orders must be accepted by the customer no later than 6 months after order placement. We are entitled to invoice the customer even if the call has not been made.

### **Variations in quantities**

We reserve the right to deliver an additional or under quantity of 2%, with special deliveries, 10%.

### **Price**

Our prices are subject to change and are understood as ex-works Factory Rheineck, plus statutory value added tax as well as packaging, customs and insurance costs.

### **Terms of payment**

Unless otherwise agreed, the settlement will be in Swiss Francs.

invoices are payable in full within 30 days of the invoice date net or within 10 days with a 2% cash discount.

A cash discount will only be granted, if all previous invoices have been settled.

If our terms are exceeded, we are entitled to charge interest at the rate which the bank charges us for our overdraft facility.

With orders above CHF 20'000.00,- one third of the order sum is payable on placing the order, one third upon readiness of ship and notification of readiness to ship to the customer and one third upon delivery. If, during the term of the contract, the buyer's financial situation deteriorates or if, in our opinion, we receive unsatisfactory information concerning the buyer which first occur following the contract termination, all payments shall be due immediately.

We shall then be entitled to demand additional securities as well as to withdraw from the contract following a reasonable time period.

We reserve the right to accept bills of exchange as payments on account. All costs arising in this regard shall be borne by the customer.

### **Retention of title**

All delivered goods remain our property up to a complete settlement of all our claims against the customer arising out of the business relationship.

The buyer is entitled to sell the items delivered in the proper course of business as long as the customer is not in default of payment, but may not be pledged as collateral or assigned.

In the case of pledges and seizure of the goods, the customer must immediately notify us. On conclusion of the sales contract with us it cedes to us the claims accruing to it from the sale or based on other legal grounds including all ancillary rights to the full amount. The customer shall retain the right to collect the receivables as long as the customer is not in default of payment to us.



If the value of demands or collateral exceeds our total demand against products subject to claim by more than 20%, we shall be obliged to back transfer upon the customer's request.

### **Liability for defects**

For any defects in the products supplied, including the absence of promised characteristics, we shall be liable in such a way that we will repair damaged/defective parts free-of-charge or deliver replacement. Defects shall be notified to us within one week of delivery. Parts free of defects must be sent to us upon request carriage paid. The shipping of replacement parts shall be done at the cost and risk of the customer. Any parts which we have replaced shall be our property. Claims for defects by the customer lapse in any case six months from the time of the timely notice of complaint but no earlier than the expiry of the liability period.

No liability will be accepted for supplied parts that are subject to premature wear and tear as a consequence of their material character or the way in which they are used, or for damage as a consequence of usual wear, straining, erroneous or negligent handling, unsuitable means of operation, defective construction, or as a consequence of the influence of temperature, the weather, chemical or electrical influences or as a consequence of other influences of nature. Other claims by the customer in particular claims for replacement of damages which were not incurred in the delivery itself, shall not be covered insofar as they are legally permitted.

Claims not expressly conceded in these conditions of sale and delivery, in particular claims for damages resulting from breach of impossibility, default, violation of contractual secondary obligations, wrongful act - also as far as such claims are tied up with the warranty rights of the customer - are excluded, unless we are preemptorily liable in case of gross negligence or malice.

If through our fault the delivered item cannot be used as provided for in the contract because of non-implementation or deficient implementation of proposals or consultation, whether made or provided before or after conclusion of the contract, or of contractually agreed collateral obligations – in particular instructions for the operation and maintenance of the delivery item – the provisions shall apply accordingly, all other claims of the customer being excluded.

### **Severance clause**

In the event that individual provisions hereof should be or become invalid, the invalid provision shall be replaced by a valid substitute provision which most closely reflects the originally-intended commercial purpose. Should individual provisions of these Terms of sale and delivery be or become invalid, the validity of the other provisions shall remain unaffected.

### **Applicable Law and Jurisdiction**

All legal relations between us the customer shall be governed by Swiss law.

The court of jurisdiction for all disputes between us and our customers is CH-9450 Altstätten. We also have the right to prosecute the customer at the responsible court of the customer's residence or any other court.

### **Transferability of contract rights**

The customer shall not assign his contractual rights to any third party without our express permission.

PEKO ROLLEN AG  
Peter Köppel  
Langenhagstrasse 13  
CH-9424 Rheineck